



**AGENDA
CITY OF CEDAR FALLS, IOWA
COMMITTEE OF THE WHOLE MEETING
MONDAY, JULY 06, 2020
6:00 PM AT CITY HALL VIA VIDEO CONFERENCE**

To protect against the spread of the COVID-19, the meeting will be held via video conference. The public may access/participate in the meeting in the following ways:

- a) By dialing the phone number +13126266799 or +19292056099 or +12532158782 or +13017158592 or +13462487799 or +16699006833 and when prompted, enter the meeting ID (access code) 962 7287 1738.
- b) iPhone one-tap: +13126266799,,96272871738# or +19292056099,,96272871738#
- c) Join via smartphone or computer using this link: <https://zoom.us/j/96272871738>.
- d) View the live stream on Channel 15 YouTube using this link: <https://www.youtube.com/channel/UCCzeig5nIS-dIEYisqah1uQ> (view only).
- e) Watch on Cedar Falls Cable Channel 15 (view only).

To request to speak when allowed on the agenda, participants must click "Raise Hand" if connected by smartphone or computer, or press *9 if connected by telephone. All participants will be muted by the presiding officer when not actually speaking.

1. Update on Potential Pool Partnership.
(25 Minutes)
2. Urban Chickens and Ducks.
(20 Minutes)
3. Bills & Payroll.
(5 Minutes)

Existing Public Pools

- Peet & Holmes pools are 43 years old. Avg Pool lasts approx 50 years
 - Dubuque pool collapsed last year at 50 yrs – community had no pool
- Peet pool on the verge of closing in next 1-2 yrs
- Peet & Holmes lack modern characteristics such as cool down/warm up areas, large staging deck, ADA compliant, separate secure entry, 8+ lanes, good air/water filtration
- Current pools lack infrastructure for large meets; CFHS had to rent Linn-Mar pool to host MVC meet due to Holmes, Peet and UNI pool inadequacies
- 1998 there were 30 lap lanes in CF; 2020 there are 20 lap lanes (33% decline); closure of Peet will reduce lanes to 14 (53% decline); Of the 14 lanes remaining only 6 are for public usage.
- CF rec study - #1 item community wanted was better aquatic facilities
- Since 1973 the women's and men's swim team has won 14 state titles; 2nd in state 6 times and 3rd 7 times. These teams have and placed 1st in conference 47 times and in the top 3 77 times.

Impact of Peet closure

- Severely strain scheduling capacity at Holmes
- Eliminate programming – scuba, lap swim, club swim decline, life guard cert, rec swim
- Elimination/decline of swim club=no feeder of lifeguards to the Falls Aquatic Center, no feeder to HS swim program
- Crippling effect on all safety programs
 - Negatively affects training swim instructors & life guards
 - Reduce swimming lesson capacity
 - Students will no longer learn to swim in school
 - Increase downing risk

Impact of new pool in community

- Economic – Bring in 1,961 visitors and \$912,000 revenue to community
- Attract young families to the community
- Utilization by community during school hours with secure independent entrance
- Competing communities such as Cedar Rapids, Dubuque, Iowa City, Des Moines and Ames have all invested into their aquatic facilities in the last few years.
- New programming – pool walk, aqua aerobics, kayaking, water polo, aqua trim, aqua therapy
- Safety – swim lessons for all Cedar Falls students
- Draw beyond CF area – next closest public pool east=Dubuque, north=Waverly, south=Cedar Rapids, west=Ft Dodge. CFHS pool will be swimming center for all surrounding communities – Oelwein, Dike, Denver, New Hartford, Hudson, Sumner, etc. The Falls has 58% non-passholders many of which are non-residents.

Collaboration possibilities

- City – HS pool design with input from city. Per city request added separate 30' by 75' pool with dedicated temperature control for senior/toddler comfort; public entrance; 3-meter platform for recreation and UNI usage; training rooms for lifeguard cert & party rentals
- UNI
- Senior Centers – NewAldaya
- Physical Therapy
- Would be 1st project in CF where community, city and school have collaborated with monetary input from all 3 groups

New Pool Opportunity - July 6, 2020



JOIN
the "Jump In"
facebook page

Points we will address

- Why does Cedar Falls need a new pool?
- Key elements of pool design
- Cost and Collaborative financing
- Timing

Pool Need in Cedar Falls

- In next 5-10 years we may not have any public indoor pools in CF.
 - Two pools both 43 years old and nearing end of life
 - Peet will close in next 1-3 years - School needs space for classrooms. Pool also in disrepair with many ventilation and/or mechanical problems.
- Modern indoor pool is a necessary part of a vibrant community
 - Essential for water safety, swim lessons, lifeguard cert.
 - Recreation and fitness for all ages
- Collaboration opportunity
- Ability to attract visitors & retain young families
 - CF already an outlier (negative)
 - Opportunity to attract 1,000+ visitor families annually

Holmes Pool Current Schedule - School Year

	Sunday	Monday	Tuesday	Wednesday	Thursday	Friday	Saturday
5:30 am							
6:00 am							
6:30 am							
7:00 am							
7:30 am							
8:00 am							
8:30 am							
9:00 am							
9:30 am							
10:00 am							
10:30 am							
11:00 am							
11:30 am							
Noon							
12:30 pm							
1:00 pm							
1:30 pm							
2:00 pm							
2:30 pm							
3:00 pm							
3:30 pm							
4:00 pm							
4:30 pm							
5:00 pm							
5:30 pm							
6:00 pm							
6:30 pm							
7:00 pm							
7:30 pm							
8:00 pm							
8:30 pm							
9:00 pm							
9:30 pm							
10:00 pm							

Rec Programming
HS Swim Practice (August 6 – February 9)
Black Hawk Area Swim Team (February 10 – June 5)
School Usage
Swim Lessons – March 2 – April 27
Private Rental Options
Times facility is not utilized

Peet Pool Current Schedule - School Year

	Sunday	Monday	Tuesday	Wednesday	Thursday	Friday	Saturday
5:30 am							
6:00 am							
6:30 am							
7:00 am							
7:30 am							
8:00 am							
8:30 am							
9:00 am							
9:30 am							
10:00 am							
10:30 am							
11:00 am							
11:30 am							
Noon							
12:30 pm							
1:00 pm							
1:30 pm							
2:00 pm							
2:30 pm							
3:00 pm							
3:30 pm							
4:00 pm							
4:30 pm							
5:00 pm							
5:30 pm							
6:00 pm							
6:30 pm							
7:00 pm							
7:30 pm							
8:00 pm							
8:30 pm							
9:00 pm							
9:30 pm							
10:00 pm							

Rec Programming
SCUBA Top – 27 th Sunday every month
Black Hawk Area Swim Team
School Usage
Swim Lessons – March 26 – April 25
Private Rental Options
Times facility is not utilized

Rec Center Survey

#1 item respondents want is improved aquatics facility/access



Key Elements of Pool Design



CEDAR FALLS HIGH SCHOOL

FUTURE POOL

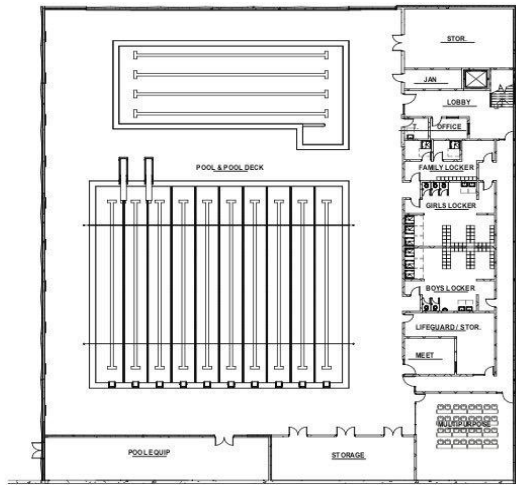

LOWER LEVEL POOL

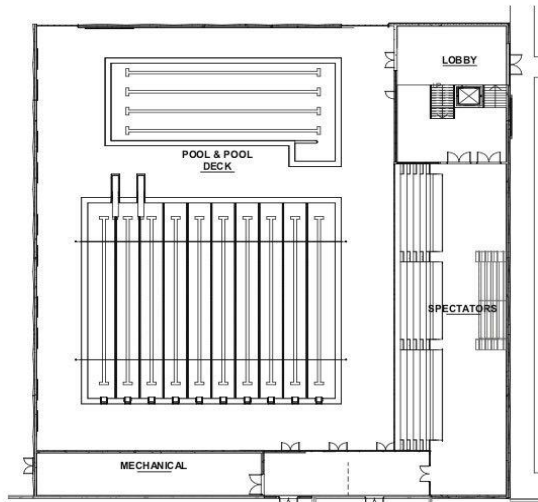

UPPER LEVEL POOL

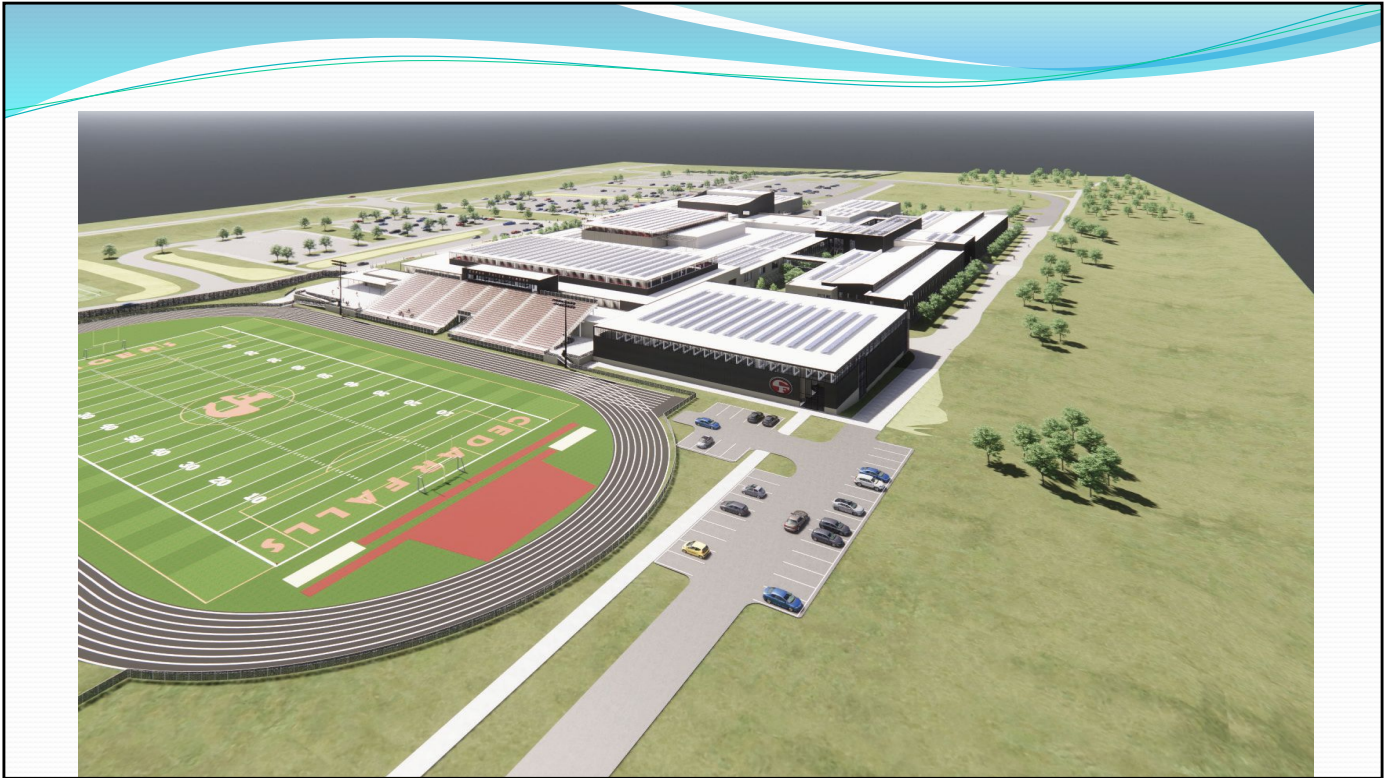

Quality of Life Opportunities

- Specialty programming for people with disabilities
- Water polo
- Aqua spinning
- Aqua trim
- Water Zumba
- Pool walking
- Lap swim
- Swim lessons
- Scuba classes
- Kayaking/Canoeing
- Lifeguard water safety instructions/CPR/first aid classes
- Diving Club
- Swim Club
- Triathletes club
- Aqua therapy for those dealing with chronic health issues such as arthritis, Parkinson's disease, fibromyalgia and joint replacements

Cost, Collaborative Financing & Timing

Cost/Funding

Estimated Construction cost
\$9-\$15 million

- Linn-Mar = 12 million
- Dubuque = 8.5 million
- Ames = \$12.7 million

Collaborative funding approach needed

- School District
- City
- Community/Philanthropy
- UNI

Collaborative Funding Proposal

School	\$8 million
City	\$3 million
Community:	
Grants	\$1 million*
Private	<u>\$1 million</u>
Total	\$13 million

*Ask both city and school to prioritize pool to Black Hawk Gaming

Impacts of New Pool to Community

- Keeping our community competitive with comparable communities
- Revenues from new pool use
 - Estimated 1,961 number of families visiting areas per year (swim meets)
 - Estimated economic impact of those swim meets \$912,000
 - High School and BLAST swimmers from other communities
 - Increased pool pass revenue
- Regional centerpiece for water activities
- Development of special needs curriculum in collaboration with UNI

Timing: Window of Opportunity

- Need
 - Peet closure
- Competition for Fundraising
 - Sportsplex project on horizon
 - Time windows for Grants -- Prioritization of Black Hawk Gaming funds
- Economies of scale
 - Cedar Falls School construction 2022-2024
 - Beneficial to build same time as new CFHS

Appendix - Additional Info

Modern Pool Characteristics vs CF Pools

Modern Pools	CF Pools
8 lanes or more	6 lanes
Cool down/Warm up area	no cool down/warm up area
Large staging deck for swimmers, coaches, guards, officials	Small staging area
Large entry area for spectators, visitors, admissions, concessions	No designated area for admissions/concessions
Seating 400-500 spectators	Seating 350 spectators and less at Peet
Good air and water filtration systems	Poor air and water filtration
Accommodate those with disabilities	Limited accommodations with disabilities at Holmes/No spectators seating with disabilities
Separate entry to pool for security and so pool can be used by public when not in school use	No separate entry
Modern starting blocks	Outdated – no wedge for starts
Scoreboard with athlete names, event name, video	No athlete names, event name, video; No scoreboard at Peet

We have a pool capacity problem

Closure of Peet will have significant negative impact

- Severely strain scheduling capacity at Holmes
- Holmes pool may not last – Dubuque’s pool collapsed at 50 yrs
- Crippling effect upon all safety & swimming programs in Cedar Falls
 - **Reduction of indoor pool space affects training of swimming instructors & lifeguards; reduces swimming lesson capacity; therefore, decreases overall community water safety and increases drowning risk**
 - Negatively affects pool time available to local swim team to train and develop swimmers who might later be lifeguards for the Falls Aquatic center or Swim instructors
- Recreational and lap swim time is less available to the community
- Reduces ability to host local swim meets
- Negative impact on our high school swimming program. CF has a proud history of excellent swimming winning 14 state championships and 47 conference titles..

Newer Pools in other Communities

- Linn Mar pool – 2 years old; 12 million stand alone facility. Stretch 25 yd pool w 8 competition lanes & 5 lane cool down area 75' X 109'
- Dubuque pool – Built 2020; 8.5 million construction – 9.5 w soft costs. Stretch 25 yd pool w 8 competition lanes & 6 lane cool down area 75' X 121'6"
- Ames pool – Under construction; est 12.7 million construction – 15.3 w soft costs. Stretch 25 yd pool w 8 competition lanes & 5 lane cool down area 75' X 115'
- Mason City – New pool as part of \$37M improvement to high school mostly athletic facilities
- Des Moines YMCA Wellmark – 50 meter pool opened Feb 2018

Pools in Other Communities – cont'd

- Iowa City Mercer - 50 meter pool
- Grinnell College – 50 meter pool; built in 2010
- Other communities in the area– Marshalltown, Fort Dodge - have better pools.
- Some smaller communities have newer pools – Decorah, Cresco

COMMUNITY PROGRAMS AT PEET

- Recreational Swim on Saturdays
 - 500+ visits annually
- Early Bird Lap Swim, MWF mornings
 - 2100+ visits annually
 - Can't be moved to Holmes due to high school practices during school year
- Scuba Sundays, 2nd Sunday monthly
 - 150 participants annually
 - Certification and recertification for scuba, snorkeling, deep sea rescue, and scuba instruction

COMMUNITY PROGRAMS AT PEET

- Swimming Lessons
 - 240 annual participants during 5 week program (March-April)
- Lifeguard Certification
 - 25 annual certifications plus 10-15 annual recertifications
- Falls Aquatic Center Skills Training
 - 130 potential staff annually

WATER SAFETY IMPACT

- Holmes Pool cannot accommodate all of these community programs
- 1500 fewer children take swimming lessons every year
- Less opportunity to train lifeguards and test staff to ensure safety at the Falls
- Less pool availability means more swimming in unsafe places

Competitive Swimming at Peet

- BLAST
 - Approximately 200 swimmers from age 6 through high school
 - 9,200 annual visits (summer and winter practices)
 - Holmes cannot accommodate BLAST practices
- USS Destroyers
 - 25 swimmers
 - 1,250 annual visits (school holidays and summers)
- Successful high school swimming programs increasingly feature
 - Swimmers who train year-round
 - Up-to-date facilities

Statistics

- Swimming is the fourth most popular recreational activity in the United States . U.S. No. 1 is walking, No. 2 spot goes to exercising with equipment and 3rd running, according to the U.S. Census Bureau.
- Swimming is the most popular recreational activity for children and teens (ages 7-17) .
- Swimming is a lifelong sport. In the United States during 2009, there were approximately 301 million swimming visits each year by persons over the age of six .
- Thirty-six percent of children aged 7-17 years, and 15% of adults in the United States, swim at least six times per year.
- **Modern, thriving and attractive communities have good indoor pools**

Statistics Continued

- From 2005-2014, there were an average of 3,536 fatal unintentional drownings (non-boating related) annually in the United States — about ten deaths per day. An additional 332 people died each year from drowning in boating-related incidents.
- About one in five people who die from drowning are children 14 and younger. For every child who dies from drowning, another five receive emergency department care for nonfatal submersion injuries.
- More than 50% of drowning victims treated in emergency departments (EDs) require hospitalization or transfer for further care (compared with a hospitalization rate of about 6% for all unintentional injuries). These nonfatal drowning injuries can cause severe brain damage that may result in long-term disabilities such as memory problems, learning disabilities, and permanent loss of basic functioning (e.g., permanent vegetative state).
- **Children:** Children ages 1 to 4 have the highest drowning rates. In 2014, among children 1 to 4 years old who died from an unintentional injury, one-third died from drowning. Drowning is responsible for more deaths among children 1-4 than any other cause except congenital anomalies (birth defects). Among those 1-14, fatal drowning remains the second-leading cause of unintentional injury-related death behind motor vehicle crashes.
- **Minorities:** Between 1999-2010, the fatal unintentional drowning rate for African Americans was significantly higher than that of whites across all ages. The disparity is widest among children 5-18 years old. The disparity is most pronounced in swimming pools; African American children 5-19 drown in swimming pools at rates 5.5 times higher than those of whites. This disparity is greatest among those 11-12 years where African Americans drown in swimming pools at rates 10 times those of whites.
- Many adults and children report that they can't swim. Research has shown that participation in formal swimming lessons can reduce the risk of drowning among children aged 1 to 4 years.

Linn Mar Pool



Dubuque Pool



Cost Sharing for Peet and Holmes

- Initial build cost of \$1.1 million for both pools.
 - City contributed approximately 10%
 - School District funded the rest
- 28E Agreement governs sharing of annual operational costs
 - City pays 45% of ongoing pool expenses (utilities, supplies, insurance, and school personnel time and costs for maintenance, upkeep, and repair)
 - 2019 total operational expense \$92,000 (45% share = \$41,000)
 - School personnel time devoted to keeping pools operating has increased dramatically in last 3 years. From 2000-2016, average annual time was 182 hours. Beginning in 2017, annual time jumped to over 300 hours, averaging 335 hours.
- In addition, city pays 100% of city program costs at Peet and Holmes (insurance, cleaning, lifeguarding and staff expenses) and funds the Aquatics Director position

2020-2021 Athletic Sharing Agreements

- For Swimming (Men's, Women's, or both):
 - Aplington-Parkersburg
 - Denver
 - Dike-New Hartford
 - Dunkerton
 - Hudson
 - Independence
 - Janesville
 - Oelwein
 - Sumner-Fredericksburg
 - Waverly-Shellrock
 - Valley Lutheran



DEPARTMENT OF COMMUNITY DEVELOPMENT

City of Cedar Falls
 220 Clay Street
 Cedar Falls, Iowa 50613
 Phone: 319-273-8600
 Fax: 319-273-8610
 www.cedarfalls.com

MEMORANDUM
Administration Division

TO: Mayor Rob Green and City Council
FROM: Stephanie Houk Sheetz, AICP, Director of Community Development
DATE: June 30, 2020
SUBJECT: Urban Chickens and Ducks

In 2006, City Council passed Ordinance 2607 including chickens in a list of agricultural animals and specifying they are only allowed in the A-1 district. Any non-agriculturally zoned property with chickens was prohibited at that time. Residences with chickens at the time were allowed to continue, provided the use was continuous and specific to that property. These amendments occurred within Chapter 6, Animals of the Cedar Falls Code of Ordinances.

In 2016, Council referred the keeping of chickens to a Committee of the Whole discussion. The result was a motion to direct staff to develop an ordinance allowing up to three chickens (hens only), keeping them in an enclosed structure and fenced pen at least 25 feet from any other dwelling, obtaining a land use permit for the structure/pen, and allowing the use in the back yard area only. The ordinance did not pass when considered in November 2016.

In 2018, Council referred the keeping of chickens to a Committee of the Whole discussion. The Council motioned to direct staff to develop an ordinance allowing chickens (hens only) and ducks in residential districts, a limit of three animals, keeping them in an enclosed structure and fenced pen at least 25 feet from any other dwelling, allowing the use in the back yard area only, and a termination clause for public health reasons. The ordinance was not approved when considered in September 2018. This seemed to be due to concern about licensing rather than a land use permit.

Council recently referred the keeping of chickens to a Committee of the Whole discussion. Enclosed is a presentation staff will cover at the July 7th meeting.

Staff's recommendation is the same as presented in 2018: start by allowing only a few chickens/ducks and license the animals. Requiring a license rather than a land use permit keeps regulations similar to those of other small animals kept in small numbers for personal use.

Land use permits apply to significant improvements that are more permanent in nature such as a new home, additions, decks, swimming pools, fences (due to easements and utilities), driveways, and large sheds. Sheds 120 square feet or less do not need a land use permit. Should a proposed structure for chickens/ducks exceed 120 square feet, then it would be subject to a land use permit. However, it is anticipated that a coop and run for up to three chickens would be around 40 square feet.¹ In the license application, staff could verify the location of the coop and fenced pen regardless of its size.

Staff will be seeking a motion from Council, on whether to proceed with an ordinance to allow the keeping of chickens and ducks.

xc: Karen Howard, Planning & Community Services Manager

¹ <https://www.dummies.com/home-garden/hobby-farming/raising-chickens/how-to-determine-your-flock-size-and-space-requirements/#:~:text=The%20minimum%20rule%20of%20thumb,pecking%2C%20and%20sometimes%20even%20death.>

Urban Chickens and Ducks Council Committee Meeting

June 30, 2020



Urban Chickens and Ducks

2016 Ordinance Research

City	Allows Chickens	Number Allowed	Approval Process
Davenport/Waukee/ Coralville/Cedar Falls/W. DSM/Ankeny/Urbandale	No	N/A	N/A
Iowa City	Yes	4	Permit
Sioux City	Yes	4	Permit
Waterloo	Yes	No limit	Permit by BOA
Dubuque/Ames	Yes	No limit	None
Clive	Yes	12	None
Marion	Yes	6	Permit
Johnston	Yes	2	Lot > 20,000 sf
Des Moines	Yes	30-50 based on lot size	None
Cedar Rapids	Yes	6	Permit

Urban Chickens and Ducks

Previous Discussion

- Council Committee discussion on August 20, 2018
- Staff recommended forwarding an ordinance with the following general standards:
 - Three chickens (hens) and/or ducks
 - Kept in a clean, sanitary and enclosed structure
 - 25-foot separation from neighboring residential dwellings
 - Allowed in residential (R) zoning districts
 - Backyard area only
 - Termination of chickens for health reasons

Urban Chickens and Ducks License

Sec. 6-44. - License required for dogs and cats.

The owners of all dogs and cats four months old or older shall annually obtain a license therefore as provided in this article.

(Code 2017, § 6-42; Ord. No. 2223, § 2, 3-23-1998)

Urban Chickens and Ducks

Coop and Fenced Pen

If 3 chickens: 9 sq. ft. (coop), 30 sq. ft (run) = 40 sq. ft.

The minimum rule of thumb is about 2 to 3 square feet per chicken inside the chicken coop, and 8 to 10 square feet per chicken in an outside run. More square footage is better. Skimping on space requirements for a flock of chickens can cause stress, cannibalism, pecking, and sometimes even death.

[Dummies, Home & garden topics](#)

Urban Chickens and Ducks Coop and Fenced Pen Examples

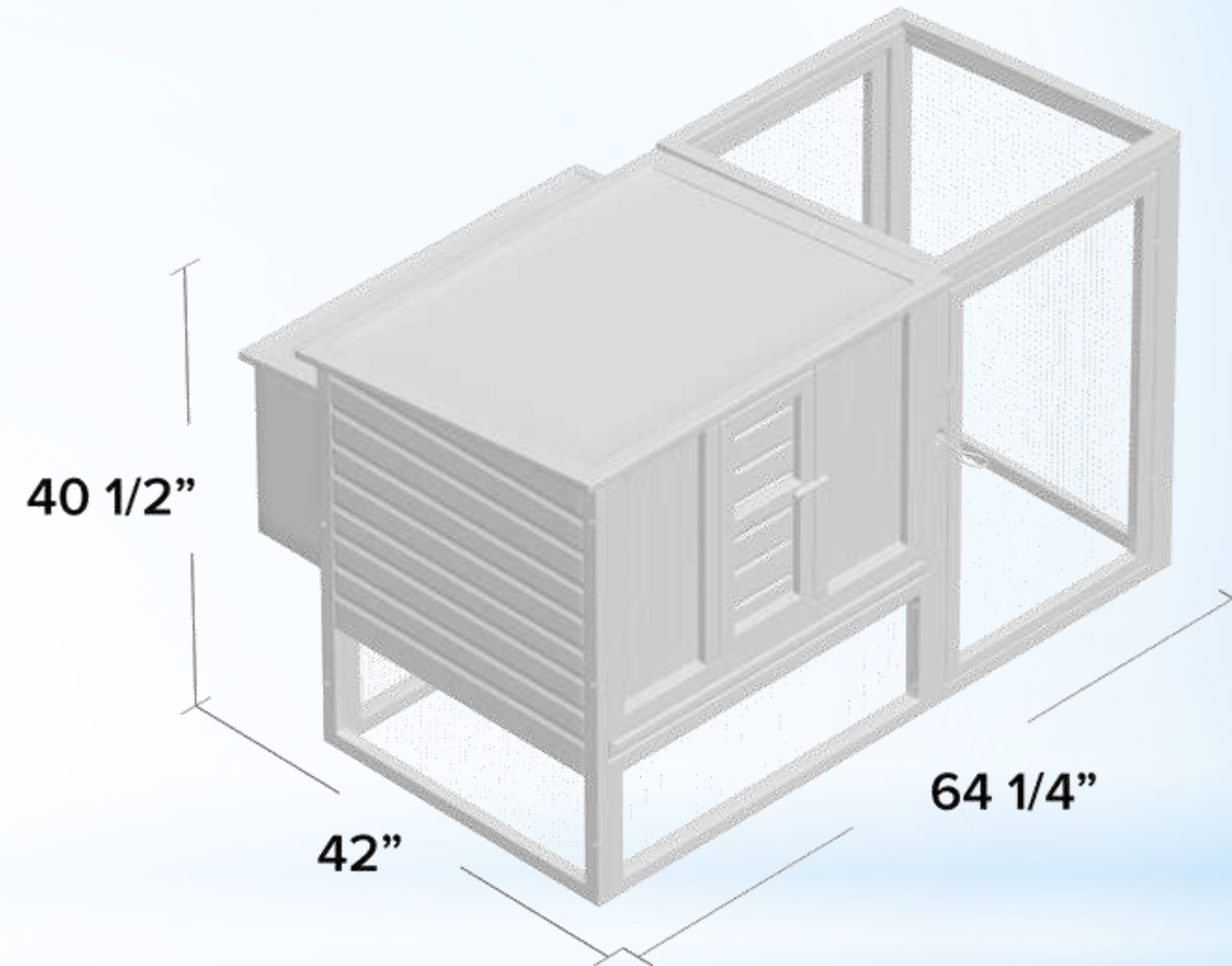

18 3/4 square feet

Urban Chickens and Ducks Coop and Fenced Pen Examples



16 2/3 square feet

Urban Chickens and Ducks Coop and Fenced Pen Examples

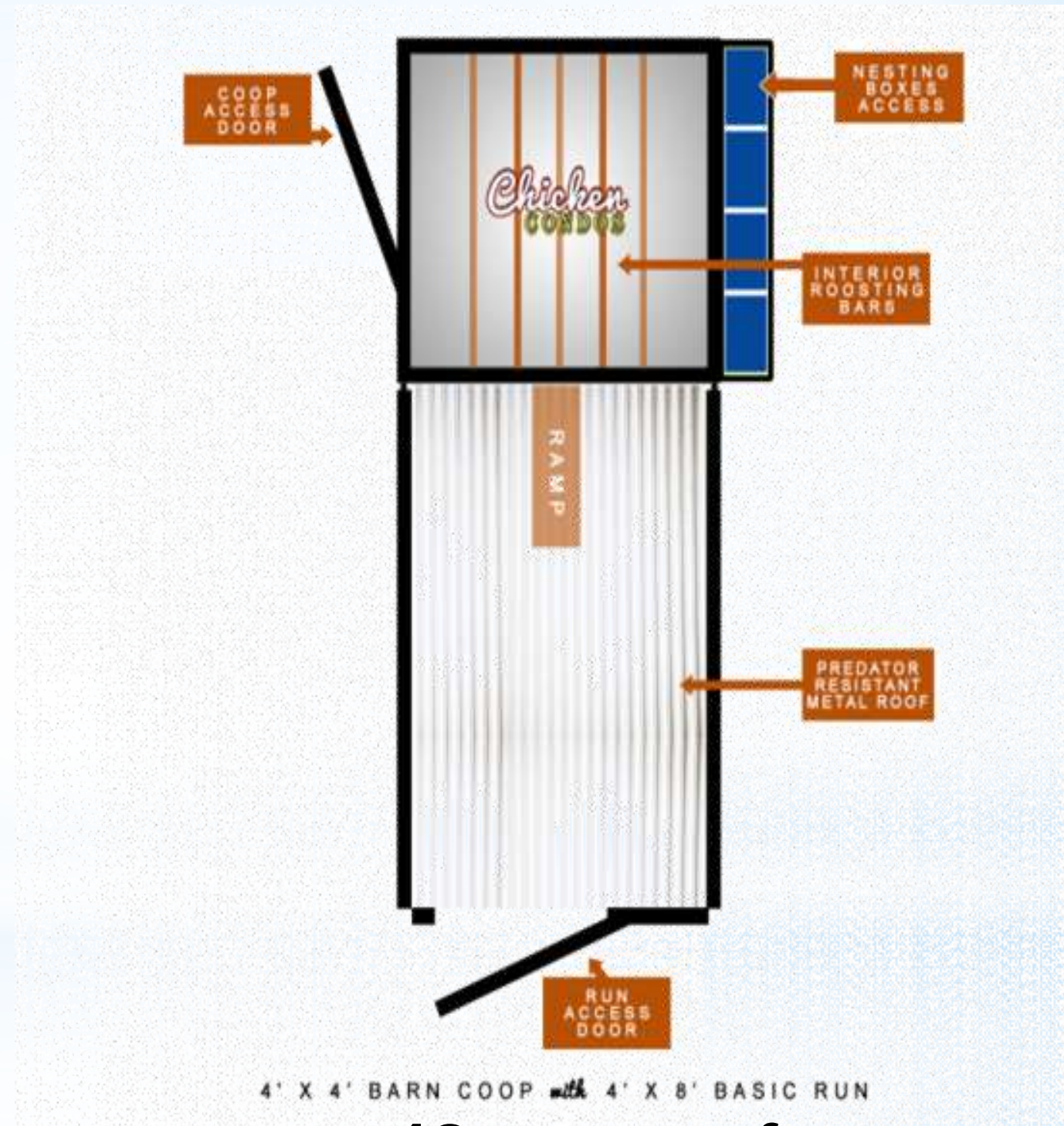

48 square feet

Urban Chickens and Ducks

Recommended Motion

Draft an ordinance with the following general standards:

- a. Three chickens (hens) and/or ducks, to be licensed annually
- b. Kept in a clean, sanitary and enclosed structure
- c. 25-foot separation from neighboring residential dwellings
- d. Allow in residential (R) zoning districts
- e. Backyard area only
- f. Termination of chickens for health reasons

Daily Invoices for Council Meeting 07/06/20
 ACCOUNT ACTIVITY LISTING

Item 3.

GROUP NBR	PO NBR	ACCTG PER.	CD	TRANSACTION DATE	NUMBER	DESCRIPTION	DEBITS	CREDITS	CURRENT BALANCE	POST DT
FUND 101 GENERAL FUND										
101-1060-423.71-01 OFFICE SUPPLIES / OFFICE SUPPLIES										
2070		12/20 AP		06/04/20	0000000	STOREY KENWORTHY	64.70			06/26/20
2070		12/20 AP		06/02/20	0000000	CLOROX DISINFECTING WIPES				06/26/20
2070		12/20 AP		06/02/20	0000000	3/4" MAGIC & REMOVABLE TAPE	162.12			06/26/20
2070		12/20 AP		06/02/20	0000000	STOREY KENWORTHY	27.30			06/26/20
2070		12/20 AP		05/28/20	0000000	3" POP-UP POST-ITS & RUBBER BANDS				06/26/20
2070		12/20 AP		05/28/20	0000000	AAA BATTERIES	18.04			06/26/20
2070		12/20 AP		05/28/20	0000000	STOREY KENWORTHY	17.08			06/26/20
2070		12/20 AP		05/27/20	0000000	10" X 13" CLASP ENVELOPES				06/26/20
2070		12/20 AP		05/27/20	0000000	STOREY KENWORTHY		30.32		06/26/20
2070		12/20 AP		05/26/20	0000000	SAFETY VEST RETURN CREDIT MEMO				06/26/20
2070		12/20 AP		05/26/20	0000000	STOREY KENWORTHY	84.00			06/26/20
2070		12/20 AP		05/19/20	0000000	BILINGUAL FLOOR DISTANCE SIGNS				06/26/20
PROJECT#:	012020									
2070		12/20 AP		05/19/20	0000000	STOREY KENWORTHY	30.32			06/26/20
						SAFETY VESTS				
						ACCOUNT TOTAL	403.56	30.32		373.24
101-1060-423.72-99 OPERATING SUPPLIES / POSTAGE										
2070		12/20 AP		05/27/20	0000000	QUADIENT FINANCE USA, INC.	304.86			06/26/20
2113		12/20 AP		05/27/20	0000000	POSTAGE				06/26/20
2070		12/20 AP		11/26/19	0000000	QUADIENT FINANCE USA, INC.	150.00			06/26/20
						POSTAGE				
2070		12/20 AP		11/26/19	0000000	PETTY CASH	4.05			06/26/20
						CERTIFIED LETTER POSTAGE				
						ACCOUNT TOTAL	458.91	0.00		458.91
101-1060-423.81-01 PROFESSIONAL SERVICES / PROFESSIONAL SERVICES										
2070		12/20 AP		06/10/20	0000000	KIMBERLY BOLAN AND ASSOCIATES	4,260.00			06/26/20
						CONSULTING FEES FOR STRATEGIC PLANNING				
						ACCOUNT TOTAL	4,260.00	0.00		4,260.00
101-1060-423.81-91 PROFESSIONAL SERVICES / LICENSES & SERVICE CONTRT										
10		01/21 AP		06/11/20	0000000	GORDON FLESCH COMPANY INC	954.24			06/26/20
						COPIER CONTRACT (1ST-21)				
						015-1483981-000				
						ACCOUNT TOTAL	954.24	0.00		954.24
101-1060-423.83-06 TRANSPORTATION&EDUCATION / EDUCATION										
2070		12/20 AP		06/01/20	0000000	IOWA LIBRARY ASSOCIATION	85.00			06/26/20
						ILA MEMB REFER CY2020				

GROUP NBR	PO NBR	ACCTG PER.	CD	DATE	TRANSACTION NUMBER	DESCRIPTION	DEBITS	CREDITS	CURRENT BALANCE	
									POST DT	
FUND 101 GENERAL FUND										
101-1060-423.83-06 TRANSPORTATION&EDUCATION / EDUCATION						continued				
2070		12/20 AP		06/01/20	0000000	IOWA LIBRARY ASSOCIATION	60.00		06/26/20	
ILA MEMB ROBERTS CY2020										
2070		12/20 AP		06/01/20	0000000	IOWA LIBRARY ASSOCIATION	125.00		06/26/20	
ILA MEMB STERN CY2020										
2070		12/20 AP		06/01/20	0000000	IOWA LIBRARY ASSOCIATION	120.00		06/26/20	
ILA MEMB STUENKEL CY2020										
ACCOUNT TOTAL							390.00	.00	390.00	
101-1060-423.85-01 UTILITIES / UTILITIES										
2070		12/20 AP		06/05/20	0000000	CEDAR FALLS UTILITIES	2,223.77		06/26/20	
LIBRARY UTILITIES										
ACCOUNT TOTAL							2,223.77	.00	2,223.77	
101-1060-423.86-01 REPAIR & MAINTENANCE / REPAIR & MAINTENANCE										
2113		12/20 AP		06/16/20	0000000	STOREY KENWORTHY	64.70		06/26/20	
PROJECT#: CLOROX DISINFECTING WIPES 012020										
ACCOUNT TOTAL							64.70	.00	64.70	
101-1060-423.89-33 MISCELLANEOUS SERVICES / FRIENDS SUPPORTED PROGRAM										
2113		12/20 AP		06/12/20	0000000	BAKER & TAYLOR BOOKS	139.86		06/26/20	
FOTL:ADULT-ADULT BOOKS										
2070		12/20 AP		06/01/20	0000000	JO-ANN STORES, LLC	1,273.00		06/26/20	
FOTL:ADULT-CREATIVEBUG SUB. 6/20-5/21										
2139		12/20 AP		04/15/20	0394455	STONE, MARGARET J		180.00	06/25/20	
VOID CHECK-EVENT CANCELED FOTL:CO-LAB-BASKET WEAVIG										
ACCOUNT TOTAL							1,412.86	180.00	1,232.86	
101-1060-423.89-34 MISCELLANEOUS SERVICES / ENDOWMENT SUPPORTED PROG.										
2136		12/20 AP		06/24/20	0000000	GROUT MUSEUM DISTRICT	150.00		06/26/20	
BERG 2 RMB SLP'20 DIGITAL DEMO X2										
2070		12/20 AP		05/21/20	0000000	SCHOLASTIC, INC.	4,988.34		06/26/20	
BERG 2 RMB SLP '20-YOUTH PRIZE BOOKS										
2139		12/20 AP		02/26/20	0394361	SPECKLED OWL, THE		340.00	06/25/20	
VOID CHECK-EVENT CANCELED RAY 2 RMB LETTER WRITING										
2139		12/20 AP		12/04/19	0394006	GROUT MUSEUM DISTRICT		450.00	06/25/20	
VOID CHECK-EVENT CANCELED BERG 2 RMB SLP '20 MAD										
1		01/21 AP		06/10/20	0000000	COMMUNITY MAIN STREET	50.00		06/26/20	
BERG 2 RMB SLP '20-GIFT CERTIFICATES										
ACCOUNT TOTAL							5,188.34	790.00	4,398.34	

GROUP NBR	PO NBR	ACCTG PER.	CD	DATE	-----TRANSACTION----- NUMBER	DESCRIPTION	DEBITS	CREDITS	CURRENT BALANCE POST DT ----
FUND 101 GENERAL FUND									
101-1061-423.71-11						OFFICE SUPPLIES / TECHNICAL PROCESSING SUPP			
2113				12/20	AP 06/15/20 0000000	DEMCO, INC	249.70		06/26/20
						DEMCO PREMIUM BOOK TAPE			
2070				12/20	AP 06/05/20 0000000	DEMCO, INC	59.90		06/26/20
						READING LEVEL LABELS			
2070				12/20	AP 02/26/20 0000000	COMPUTYPE, INC.	1,020.34		06/26/20
						TS905 2-LABEL SET			
2070				12/20	AP 02/20/20 0000000	COMPUTYPE, INC.	121.12		06/26/20
						LABEL PRINTER INK			
						ACCOUNT TOTAL	1,451.06	.00	1,451.06
101-1061-423.81-91 PROFESSIONAL SERVICES / LICENSES & SERVICE CONTRT									
2070				12/20	AP 06/01/20 0000000	OCLC, INC.	729.27		06/26/20
						CATLG & METADTA MNTLY SUB			
2128				12/20	AP 05/01/20 0394554	OCLC, INC.		729.27	06/24/20
						VOID CHECK-DUPLICATE			
						CATLG & METADTA MNTLY SUB			
						ACCOUNT TOTAL	729.27	729.27	.00
101-1061-423.89-20 MISCELLANEOUS SERVICES / ADULT BOOKS									
2113				12/20	AP 06/18/20 0000000	BAKER & TAYLOR BOOKS	493.17		06/26/20
						ADULT BOOKS			
2113				12/20	AP 06/16/20 0000000	BAKER & TAYLOR BOOKS	298.25		06/26/20
						ADULT BOOKS			
2113				12/20	AP 06/12/20 0000000	BAKER & TAYLOR BOOKS	372.57		06/26/20
						ADULT BOOKS			
2113				12/20	AP 06/12/20 0000000	BAKER & TAYLOR BOOKS	475.53		06/26/20
						ADULT BOOKS			
2113				12/20	AP 06/11/20 0000000	BAKER & TAYLOR BOOKS	129.66		06/26/20
						ADULT BOOKS			
2070				12/20	AP 06/09/20 0000000	BAKER & TAYLOR BOOKS	370.91		06/26/20
						ADULT BOOKS			
2070				12/20	AP 06/05/20 0000000	BAKER & TAYLOR BOOKS	260.69		06/26/20
						ADULT BOOKS			
2070				12/20	AP 06/05/20 0000000	BAKER & TAYLOR BOOKS	154.90		06/26/20
						ADULT BOOKS			
2070				12/20	AP 06/03/20 0000000	BAKER & TAYLOR BOOKS	83.25		06/26/20
						ADULT BOOKS			
2070				12/20	AP 06/02/20 0000000	BAKER & TAYLOR BOOKS	308.75		06/26/20
						ADULT BOOKS			
2070				12/20	AP 05/30/20 0000000	BAKER & TAYLOR BOOKS	246.24		06/26/20
						ADULT BOOKS			
2070				12/20	AP 05/28/20 0000000	BAKER & TAYLOR BOOKS	342.76		06/26/20
						ADULT BOOKS			
2070				12/20	AP 05/27/20 0000000	BAKER & TAYLOR BOOKS	236.10		06/26/20
						ADULT BOOKS			
2070				12/20	AP 05/27/20 0000000	BAKER & TAYLOR BOOKS	288.53		06/26/20

GROUP	PO	ACCTG	-----TRANSACTION-----			DESCRIPTION	DEBITS	CREDITS	CURRENT
NBR	NBR	PER.	CD	DATE	NUMBER			BALANCE	
									POST DT
FUND 101 GENERAL FUND									
101-1061-423.89-20 MISCELLANEOUS SERVICES / ADULT BOOKS						continued			
ADULT BOOKS									
2070		12/20	AP	05/21/20	0000000	BAKER & TAYLOR BOOKS	304.71		06/26/20
ADULT BOOKS									
2070		12/20	AP	05/21/20	0000000	BAKER & TAYLOR BOOKS	108.54		06/26/20
ADULT BOOKS									
ACCOUNT TOTAL							4,474.56	.00	4,474.56
101-1061-423.89-21 MISCELLANEOUS SERVICES / YOUNG ADULT BOOKS									
2113		12/20	AP	06/18/20	0000000	BAKER & TAYLOR BOOKS	32.13		06/26/20
YOUNG ADULT BOOKS									
2113		12/20	AP	06/12/20	0000000	BAKER & TAYLOR BOOKS	30.95		06/26/20
YOUNG ADULT BOOKS									
2113		12/20	AP	06/11/20	0000000	BAKER & TAYLOR BOOKS	45.04		06/26/20
YOUNG ADULT BOOKS									
2070		12/20	AP	06/09/20	0000000	BAKER & TAYLOR BOOKS	320.95		06/26/20
YOUNG ADULT BOOKS									
2070		12/20	AP	06/05/20	0000000	BAKER & TAYLOR BOOKS	35.26		06/26/20
YOUNG ADULT BOOKS									
2070		12/20	AP	06/03/20	0000000	BAKER & TAYLOR BOOKS	780.64		06/26/20
YOUNG ADULT BOOKS									
2070		12/20	AP	06/02/20	0000000	BAKER & TAYLOR BOOKS	5.99		06/26/20
YOUNG ADULT BOOKS									
2070		12/20	AP	05/30/20	0000000	BAKER & TAYLOR BOOKS	119.96		06/26/20
YOUNG ADULT BOOKS									
2070		12/20	AP	05/28/20	0000000	BAKER & TAYLOR BOOKS	17.98		06/26/20
YOUNG ADULT BOOKS									
2070		12/20	AP	05/27/20	0000000	BAKER & TAYLOR BOOKS	51.90		06/26/20
YOUNG ADULT BOOKS									
2070		12/20	AP	05/27/20	0000000	BAKER & TAYLOR BOOKS	115.75		06/26/20
YOUNG ADULT BOOKS									
2070		12/20	AP	05/26/20	0000000	BAKER & TAYLOR BOOKS	400.37		06/26/20
YOUNG ADULT BOOKS									
2070		12/20	AP	05/21/20	0000000	BAKER & TAYLOR BOOKS	11.98		06/26/20
YOUNG ADULT BOOKS									
2070		12/20	AP	05/21/20	0000000	BAKER & TAYLOR BOOKS	308.50		06/26/20
YOUNG ADULT BOOKS									
ACCOUNT TOTAL							2,277.40	.00	2,277.40
101-1061-423.89-22 MISCELLANEOUS SERVICES / YOUTH BOOKS									
2113		12/20	AP	06/19/20	0000000	BAKER & TAYLOR BOOKS	464.93		06/26/20
YOUTH BOOKS									
2113		12/20	AP	06/18/20	0000000	BAKER & TAYLOR BOOKS	20.70		06/26/20
YOUTH BOOKS									
2113		12/20	AP	06/16/20	0000000	BAKER & TAYLOR BOOKS	104.97		06/26/20
YOUTH BOOKS									

GROUP	PO	ACCTG	-----TRANSACTION-----						
NBR	NBR	PER.	CD	DATE	NUMBER	DESCRIPTION	DEBITS	CREDITS	CURRENT BALANCE POST DT
FUND 101 GENERAL FUND									
101-1061-423.89-22 MISCELLANEOUS SERVICES / YOUTH BOOKS						continued			
2113		12/20	AP	06/12/20	0000000	BAKER & TAYLOR BOOKS	31.65		06/26/20
						YOUTH BOOKS			
2113		12/20	AP	06/12/20	0000000	BAKER & TAYLOR BOOKS	26.31		06/26/20
						YOUTH BOOKS			
2113		12/20	AP	06/11/20	0000000	BAKER & TAYLOR BOOKS	74.91		06/26/20
						YOUTH BOOKS			
2070		12/20	AP	06/09/20	0000000	BAKER & TAYLOR BOOKS	75.21		06/26/20
						YOUTH BOOKS			
2070		12/20	AP	06/05/20	0000000	BAKER & TAYLOR BOOKS	117.79		06/26/20
						YOUTH BOOKS			
2070		12/20	AP	06/03/20	0000000	BAKER & TAYLOR BOOKS	66.99		06/26/20
						YOUTH BOOKS			
2070		12/20	AP	06/02/20	0000000	BAKER & TAYLOR BOOKS	49.03		06/26/20
						YOUTH BOOKS			
2070		12/20	AP	06/01/20	0000000	BAKER & TAYLOR BOOKS	668.07		06/26/20
						YOUTH BOOKS			
2070		12/20	AP	05/30/20	0000000	BAKER & TAYLOR BOOKS	70.30		06/26/20
						YOUTH BOOKS			
2070		12/20	AP	05/28/20	0000000	BAKER & TAYLOR BOOKS	43.23		06/26/20
						YOUTH BOOKS			
2070		12/20	AP	05/27/20	0000000	BAKER & TAYLOR BOOKS	71.33		06/26/20
						YOUTH BOOKS			
2070		12/20	AP	05/27/20	0000000	BAKER & TAYLOR BOOKS	57.83		06/26/20
						YOUTH BOOKS			
2070		12/20	AP	05/21/20	0000000	BAKER & TAYLOR BOOKS	19.56		06/26/20
						YOUTH BOOKS			
2070		12/20	AP	05/21/20	0000000	BAKER & TAYLOR BOOKS	975.33		06/26/20
						YOUTH BOOKS			
2070		12/20	AP	05/21/20	0000000	BAKER & TAYLOR BOOKS	61.53		06/26/20
						YOUTH BOOKS			
2070		12/20	AP	05/21/20	0000000	LIBRARY IDEAS, LLC	641.20		06/26/20
						YOUTH BOOKS			
						ACCOUNT TOTAL	3,640.87	.00	3,640.87
101-1061-423.89-23 MISCELLANEOUS SERVICES / LARGE PRINT BOOKS									
2113		12/20	AP	06/18/20	0000000	BAKER & TAYLOR BOOKS	38.99		06/26/20
						LARGE PRINT BOOKS			
2070		12/20	AP	06/05/20	0000000	CENGAGE LEARNING INC	30.39		06/26/20
						LARGE PRINT BOOKS			
2070		12/20	AP	06/02/20	0000000	BAKER & TAYLOR BOOKS	16.80		06/26/20
						LARGE PRINT BOOKS			
2070		12/20	AP	05/28/20	0000000	BAKER & TAYLOR BOOKS	16.80		06/26/20
						LARGE PRINT BOOKS			
						ACCOUNT TOTAL	102.98	.00	102.98

GROUP	PO	ACCTG	-----TRANSACTION-----						
NBR	NBR	PER.	CD	DATE	NUMBER	DESCRIPTION	DEBITS	CREDITS	CURRENT BALANCE POST DT
FUND 101 GENERAL FUND									
101-1061-423.89-24 MISCELLANEOUS SERVICES / ADULT AUDIO									
2113		12/20	AP	06/16/20	0000000	BAKER & TAYLOR BOOKS	38.48		06/26/20
						ADULT CD BOOKS			
2113		12/20	AP	06/16/20	0000000	BAKER & TAYLOR ENTERTAINMENT	27.16		06/26/20
						ADULT CD MUSIC			
2113		12/20	AP	06/16/20	0000000	FINDAWAY WORLD LLC	67.49		06/26/20
						ADULT PLAYAWAY AUDIO			
2070		12/20	AP	06/09/20	0000000	BAKER & TAYLOR ENTERTAINMENT	24.23		06/26/20
						ADULT CD MUSIC			
2070		12/20	AP	05/22/20	0000000	BAKER & TAYLOR ENTERTAINMENT	10.28		06/26/20
						ADULT CD MUSIC			
2070		12/20	AP	05/21/20	0000000	BAKER & TAYLOR BOOKS	22.00		06/26/20
						ADULT CD BOOKS			
ACCOUNT TOTAL							189.64	0.00	189.64
101-1061-423.89-25 MISCELLANEOUS SERVICES / ADULT VIDEO									
2113		12/20	AP	06/19/20	0000000	BAKER & TAYLOR ENTERTAINMENT	16.30		06/26/20
						ADULT VIDEOS			
2113		12/20	AP	06/18/20	0000000	BAKER & TAYLOR ENTERTAINMENT	241.19		06/26/20
						ADULT VIDEOS			
2113		12/20	AP	06/17/20	0000000	BAKER & TAYLOR ENTERTAINMENT	4.33		06/26/20
						ADULT VIDEOS			
2113		12/20	AP	06/17/20	0000000	BAKER & TAYLOR ENTERTAINMENT	32.57		06/26/20
						ADULT VIDEOS			
2113		12/20	AP	06/15/20	0000000	BAKER & TAYLOR ENTERTAINMENT	290.39		06/26/20
						ADULT VIDEOS			
2070		12/20	AP	06/09/20	0000000	BAKER & TAYLOR ENTERTAINMENT	115.96		06/26/20
						ADULT VIDEOS			
2070		12/20	AP	06/08/20	0000000	BAKER & TAYLOR ENTERTAINMENT	299.71		06/26/20
						ADULT VIDEOS			
2070		12/20	AP	05/29/20	0000000	BAKER & TAYLOR ENTERTAINMENT	334.68		06/26/20
						ADULT VIDEOS			
2070		12/20	AP	05/28/20	0000000	MIDWEST TAPE, LLC	89.96		06/26/20
						ADULT VIDEOS			
2070		12/20	AP	05/27/20	0000000	MIDWEST TAPE, LLC	194.92		06/26/20
						ADULT VIDEOS			
ACCOUNT TOTAL							1,620.01	0.00	1,620.01
101-1061-423.89-26 MISCELLANEOUS SERVICES / NON-PRINT RESOURCES									
2113		12/20	AP	06/17/20	0000000	RECORDED BOOKS, LLC.	56.99		06/26/20
						YOUNG ADULT VIDEO GAMES			
2113		12/20	AP	06/17/20	0000000	RECORDED BOOKS, LLC.	126.98		06/26/20
						ADULT VIDEO GAMES			
2113		12/20	AP	06/17/20	0000000	RECORDED BOOKS, LLC.	410.74		06/26/20
						ADULT VIDEO GAMES			
2113		12/20	AP	06/17/20	0000000	RECORDED BOOKS, LLC.	90.16		06/26/20
						ADULT VIDEO GAMES			

GROUP NBR	PO NBR	ACCTG PER.	CD	DATE	---TRANSACTION--- NUMBER	DESCRIPTION	DEBITS	CREDITS	CURRENT BALANCE	POST DT
FUND 101 GENERAL FUND										
101-1061-423.89-26 MISCELLANEOUS SERVICES / NON-PRINT RESOURCES						continued				
2070				12/20	AP 06/10/20 0000000	YOUNG ADULT VIDEO GAMES RECORDED BOOKS, LLC.	96.98			06/26/20
2070				12/20	AP 05/27/20 0000000	ADULT VIDEO GAMES RECORDED BOOKS, LLC.	46.99			06/26/20
2070				12/20	AP 05/20/20 0000000	YOUNG ADULT VIDEO GAMES RECORDED BOOKS, LLC.	86.98			06/26/20
2070				12/20	AP 05/20/20 0000000	ADULT VIDEO GAMES RECORDED BOOKS, LLC.	66.99			06/26/20
1				01/21	AP 05/13/20 0000000	ADULT VIDEO GAMES PROQUEST, LLC	3,500.00			06/26/20
						NEWSPAPERS.COM-IOWA SUB. 05/01/20-06/30/21				
ACCOUNT TOTAL							4,482.81	.00		4,482.81
101-1061-423.89-31 MISCELLANEOUS SERVICES / PERIODICALS										
1				01/21	AP 07/01/20 0000000	SCHOOL LIBRARY JOURNAL	136.99			06/26/20
						SCHOOL LIBRARY JOURNAL 1Y SUB 07/20-06/21				
1				01/21	AP 06/01/20 0000000	OUR IOWA MAGAZINE	19.98			06/26/20
						OUR IA FY21 SUBSCRIPTION				
ACCOUNT TOTAL							156.97	.00		156.97
101-1061-423.89-36 MISCELLANEOUS SERVICES / YOUTH VIDEO										
2113				12/20	AP 06/16/20 0000000	FINDAWAY WORLD LLC	759.95			06/26/20
2070				12/20	AP 06/05/20 0000000	YOUTH LAUNCHPADS MIDWEST TAPE, LLC	221.15			06/26/20
2070				12/20	AP 05/29/20 0000000	YOUTH VIDEOS BAKER & TAYLOR ENTERTAINMENT	16.65			06/26/20
2070				12/20	AP 05/27/20 0000000	YOUTH VIDEOS MIDWEST TAPE, LLC	16.49			06/26/20
2070				12/20	AP 05/22/20 0000000	YOUTH VIDEOS BAKER & TAYLOR ENTERTAINMENT	14.49			06/26/20
						YOUTH VIDEOS				
ACCOUNT TOTAL							1,028.73	.00		1,028.73
101-1061-423.89-37 MISCELLANEOUS SERVICES / YOUNG ADULT AUDIO										
2113				12/20	AP 06/12/20 0000000	BAKER & TAYLOR BOOKS	28.49			06/26/20
2113				12/20	AP 06/11/20 0000000	YOUNG ADULT CD BOOKS BAKER & TAYLOR BOOKS	24.75			06/26/20
2070				12/20	AP 06/02/20 0000000	YOUNG ADULT CD BOOKS BAKER & TAYLOR BOOKS	24.74			06/26/20
2070				12/20	AP 05/30/20 0000000	YOUNG ADULT CD BOOKS BAKER & TAYLOR BOOKS	21.99			06/26/20
2070				12/20	AP 05/26/20 0000000	YOUNG ADULT CD BOOKS BAKER & TAYLOR BOOKS	15.94			06/26/20

GROUP NBR	PO NBR	ACCTG PER.	CD	DATE	TRANSACTION NUMBER	DESCRIPTION	DEBITS	CREDITS	CURRENT BALANCE	POST DT
FUND 101 GENERAL FUND										
101-1061-423.89-37 MISCELLANEOUS SERVICES / YOUNG ADULT AUDIO						continued				
YOUNG ADULT CD BOOKS										
ACCOUNT TOTAL							115.91	.00	115.91	
101-1061-423.89-38 MISCELLANEOUS SERVICES / YOUNG ADULT VIDEO										
2070		12/20 AP		06/09/20	0000000	BAKER & TAYLOR ENTERTAINMENT	28.99		06/26/20	
YOUNG ADULT VIDEOS										
2070		12/20 AP		05/29/20	0000000	BAKER & TAYLOR ENTERTAINMENT	25.36		06/26/20	
YOUNG ADULT VIDEOS										
ACCOUNT TOTAL							54.35	.00	54.35	
101-1061-423.89-42 MISCELLANEOUS SERVICES / ADULT E-MATERIALS										
2113		12/20 AP		06/16/20	0000000	OVERDRIVE, INC.	65.00		06/26/20	
ADULT E-BOOKS										
2113		12/20 AP		06/16/20	0000000	OVERDRIVE, INC.	65.00		06/26/20	
ADULT E-BOOKS										
2113		12/20 AP		06/16/20	0000000	OVERDRIVE, INC.	27.50		06/26/20	
ADULT E-BOOKS										
2113		12/20 AP		06/16/20	0000000	OVERDRIVE, INC.	24.99		06/26/20	
ADULT E-BOOKS										
2113		12/20 AP		06/16/20	0000000	OVERDRIVE, INC.	27.50		06/26/20	
ADULT E-BOOKS										
2070		12/20 AP		06/11/20	0000000	OVERDRIVE, INC.	636.97		06/26/20	
ADULT E-BOOKS										
2070		12/20 AP		06/04/20	0000000	OVERDRIVE, INC.	538.62		06/26/20	
ADULT E-BOOKS										
2070		12/20 AP		06/03/20	0000000	OVERDRIVE, INC.	328.41		06/26/20	
ADULT E-BOOKS										
ACCOUNT TOTAL							1,713.99	.00	1,713.99	
101-1061-423.89-46 MISCELLANEOUS SERVICES / YOUTH E-MATERIALS										
2113		12/20 AP		06/16/20	0000000	OVERDRIVE, INC.	17.50		06/26/20	
YOUTH E-BOOKS										
2070		12/20 AP		06/09/20	0000000	OVERDRIVE, INC.	95.46		06/26/20	
YOUTH E-BOOKS										
2070		12/20 AP		06/03/20	0000000	OVERDRIVE, INC.	1,069.47		06/26/20	
YOUTH E-BOOKS										
ACCOUNT TOTAL							1,182.43	.00	1,182.43	
101-1061-423.93-01 EQUIPMENT / EQUIPMENT										
2113		12/20 AP		06/11/20	0000000	CDW GOVERNMENT, INC.	1,821.04		06/26/20	
CHROMBOXES, KEYBOARDS, &										
MICE										

GROUP NBR	PO NBR	ACCTG PER.	CD	DATE	TRANSACTION NUMBER	DESCRIPTION	DEBITS	CREDITS	CURRENT BALANCE	POST DT
FUND 101 GENERAL FUND										
101-1061-423.93-01 EQUIPMENT / EQUIPMENT						continued				
2113		12/20 AP		06/11/20	0000000	E-IMAGE DATA CORP	6,220.50			06/26/20
						MICROFILM READER				
2070		12/20 AP		06/03/20	0000000	CDW GOVERNMENT, INC.	26.90			06/26/20
						COMPUTER CABLES				
2070		12/20 AP		05/28/20	0000000	CDW GOVERNMENT, INC.	20.82			06/26/20
						USB HUB FOR MICROSOFT SURFACE				
2070		12/20 AP		05/13/20	0000000	CDW GOVERNMENT, INC.	428.65			06/26/20
						AVERMEDIA LIVE STREAMER CAM 313				
PROJECT#:				012020						
ACCOUNT TOTAL							8,517.91	.00		8,517.91
101-1199-431.88-01 OUTSIDE AGENCIES / MET - CF DISABLED										
2119		12/20 AP		06/30/20	0394607	METROPOLITAN TRANSIT AUTHORIT	352.13			06/23/20
						PAYMENT FOR FY20-FNL.PMT.				
ACCOUNT TOTAL							352.13	.00		352.13
101-1199-431.88-02 OUTSIDE AGENCIES / MET-RTC										
2119		12/20 AP		06/30/20	0394607	METROPOLITAN TRANSIT AUTHORIT	234.77			06/23/20
						PAYMENT FOR FY20-FNL.PMT.				
ACCOUNT TOTAL							234.77	.00		234.77
101-1199-431.88-11 OUTSIDE AGENCIES / MET TRANSIT AUTHORITY										
2119		12/20 AP		06/30/20	0394607	METROPOLITAN TRANSIT AUTHORIT	3,340.86			06/23/20
						PAYMENT FOR FY20-FNL.PMT.				
ACCOUNT TOTAL							3,340.86	.00		3,340.86
101-1199-431.88-12 OUTSIDE AGENCIES / MET CAPITAL REPLACEMENT										
2119		12/20 AP		06/30/20	0394607	METROPOLITAN TRANSIT AUTHORIT		300.88		06/23/20
						PAYMENT FOR FY20-FNL.PMT.				
ACCOUNT TOTAL							.00	300.88		300.88-
101-1199-431.88-19 OUTSIDE AGENCIES / MET-ROUTE 9										
2119		12/20 AP		06/30/20	0394607	METROPOLITAN TRANSIT AUTHORIT	32,164.12			06/23/20
						PAYMENT FOR FY20-FNL.PMT.				
ACCOUNT TOTAL							32,164.12	.00		32,164.12
101-1199-441.81-03 PROFESSIONAL SERVICES / RECORDING FEES										

GROUP NBR	PO NBR	ACCTG PER.	CD	DATE	-----TRANSACTION----- NUMBER	DESCRIPTION	DEBITS	CREDITS	CURRENT BALANCE POST DT ----
FUND 101 GENERAL FUND									
101-1199-441.81-03 PROFESSIONAL SERVICES / RECORDING FEES						continued			
2137		12/20 AP		06/23/20	0394615	BLACK HAWK CO.RECORDER	72.00		06/25/20
						RCD:STRM.WTR.MAINT.& RPR. AGRMT.-J.DAVIS PROPERTIES			
2137		12/20 AP		06/23/20	0394615	BLACK HAWK CO.RECORDER	37.00		06/25/20
						RCD:UTIL.EASEMENT ENCRHMT AGRMT.-J.DAVIS PROPERTIES			
ACCOUNT TOTAL							109.00	.00	109.00
101-1199-441.89-13 MISCELLANEOUS SERVICES / CONTINGENCY									
2108		12/20 AP		06/01/20	0394597	CEDAR FALLS UTILITIES	61.79		06/19/20
						UTILITIES THRU 06/01/20			
ACCOUNT TOTAL							61.79	.00	61.79
101-2245-442.89-79 MISCELLANEOUS SERVICES / SINGLE FAM CONV INCENTIVE									
2108		12/20 AP		06/18/20	0394601	MICHAEL AND JEAN NIES	5,000.00		06/19/20
						1/2 DNPMT.RENT.CONV.INCNT 2604 IOWA STREET			
ACCOUNT TOTAL							5,000.00	.00	5,000.00
101-2253-423.85-01 UTILITIES / UTILITIES									
2108		12/20 AP		06/01/20	0394597	CEDAR FALLS UTILITIES	2,347.26		06/19/20
						UTILITIES THRU 06/01/20			
ACCOUNT TOTAL							2,347.26	.00	2,347.26
101-2253-423.85-05 UTILITIES / POOL UTILITIES									
2108		12/20 AP		06/01/20	0394597	CEDAR FALLS UTILITIES	15,893.35		06/19/20
						UTILITIES THRU 06/01/20			
ACCOUNT TOTAL							15,893.35	.00	15,893.35
101-2253-423.89-14 MISCELLANEOUS SERVICES / REFUNDS									
2174		12/20 AP		06/29/20	0394636	PRAIRIE LAKES CHURCH	715.00		07/01/20
						REFUND-FALLS RENTAL			
2156		12/20 AP		06/24/20	0394625	FRIENDS OF THE FAMILY	200.00		06/29/20
						REFUND-PTL. S-BALL LEAGUE			
2119		12/20 AP		06/22/20	0394610	WILBOS	225.00		06/23/20
						REFUND-ADULT SBALL LEAGUE			
2119		12/20 AP		06/22/20	0394611	WILBOS	200.00		06/23/20
						REFUND-PTL. S-BALL LEAGUE			
2128		12/20 AP		06/22/20	0394611	WILBOS		200.00	06/24/20
						VOID CHECK-CHANGE VENDOR REFUND-PTL.S-BALL LEAGUE			
2137		12/20 AP		06/22/20	0394618	JAY GOULDEN	200.00		06/25/20
						REFUND-PTL. S-BALL LEAGUE RE-ISSUE CK# 394611			

GROUP	PO	ACCTG	----TRANSACTION----				DEBITS	CREDITS	CURRENT
NBR	NBR	PER.	CD	DATE	NUMBER	DESCRIPTION			BALANCE
									POST DT
FUND 101 GENERAL FUND									
101-2253-423.89-14 MISCELLANEOUS SERVICES / REFUNDS						continued			
2108		12/20	AP	06/18/20	0394593	AMY MORSE	68.00		06/19/20
						REFUND-SWIM LESSONS			
2085		12/20	AP	06/16/20	0394588	STEVE BERNARD	200.00		06/17/20
						REFUND-PTL. S-BALL LEAGUE			
2085		12/20	AP	06/15/20	0394587	MICHAEL SCHULLER	200.00		06/17/20
						REFUND-PTL. S-BALL LEAGUE			
2068		12/20	AP	06/11/20	0394583	WILD HARE	200.00		06/15/20
						REFUND-PTL. S-BALL LEAGUE			
2068		12/20	AP	06/11/20	0394579	CEDAR FALLS CLASS OF 1960	22.00		06/15/20
						REFUND-SHELTER RENTAL			
2068		12/20	AP	06/10/20	0394581	VIKING PUMP	200.00		06/15/20
						REFUND-PTL. S-BALL LEAGUE			
2068		12/20	AP	06/10/20	0394582	WILBOS BURGERS	200.00		06/15/20
						REFUND-PTL. S-BALL LEAGUE			
						ACCOUNT TOTAL	2,630.00	200.00	2,430.00
101-2280-423.72-70 OPERATING SUPPLIES / CLASSROOM SUPPLIES									
2128		12/20	AP	07/11/17	0317606	MASKE, JOYANN		25.12	06/24/20
						VOID-CHECK LOST			
						RMB:FIELD TRIP SUPPLIES			
						ACCOUNT TOTAL	.00	25.12	25.12-
101-2280-423.85-01 UTILITIES / UTILITIES									
2108		12/20	AP	06/01/20	0394597	CEDAR FALLS UTILITIES	398.54		06/19/20
						UTILITIES THRU 06/01/20			
						ACCOUNT TOTAL	398.54	.00	398.54
101-2280-423.89-14 MISCELLANEOUS SERVICES / REFUNDS									
2137		12/20	AP	06/23/20	0394613	ANGIE LINDLEY	115.00		06/25/20
						REFUND-WORKSHOP CANCELLED			
						CITY BUILDINGS CLOSED			
						ACCOUNT TOTAL	115.00	.00	115.00
101-4511-414.83-06 TRANSPORTATION&EDUCATION / EDUCATION									
2128		12/20	AP	06/11/19	0393102	LADAGE, ZACH		26.74	06/24/20
						VOID-CHECK LOST			
						RMB:EMT PREMIUM APP.			
						ACCOUNT TOTAL	.00	26.74	26.74-
101-4511-414.85-01 UTILITIES / UTILITIES									
2174		12/20	AP	06/15/20	0394633	CEDAR FALLS UTILITIES	203.75		07/01/20
						UTILITIES THRU 06/15/20			

GROUP NBR	PO NBR	ACCTG PER.	CD	DATE	TRANSACTION NUMBER	DESCRIPTION	DEBITS	CREDITS	CURRENT BALANCE	
									POST DT	
FUND 101 GENERAL FUND										
101-4511-414.85-01 UTILITIES / UTILITIES						continued				
2108		12/20 AP		06/01/20	0394597	CEDAR FALLS UTILITIES	770.25		06/19/20	
UTILITIES THRU 06/01/20										
ACCOUNT TOTAL							974.00	.00	974.00	
101-5521-415.72-01 OPERATING SUPPLIES / OPERATING SUPPLIES										
2174		12/20 AP		06/15/20	0394633	CEDAR FALLS UTILITIES	32.95		07/01/20	
UTILITIES THRU 06/15/20										
2108		12/20 AP		06/01/20	0394597	CEDAR FALLS UTILITIES	130.53		06/19/20	
UTILITIES THRU 06/01/20										
ACCOUNT TOTAL							163.48	.00	163.48	
101-5521-415.72-20 OPERATING SUPPLIES / OFFICERS EQUIPMENT										
2128		12/20 AP		07/23/18	0393028	LADAGE, ZACH		136.75	06/24/20	
VOID-CHECK LOST						RMB:OPT.EQUIP-POUCHES+				
ACCOUNT TOTAL							.00	136.75	136.75-	
101-5521-415.83-05 TRANSPORTATION&EDUCATION / TRAVEL (FOOD/MILEAGE/LOD)										
2128		12/20 AP		08/15/19	0393372	GETZ, JOSH		14.52	06/24/20	
VOID-CHECK LOST						RMB:MEAL-ILEA TESTING				
2128		12/20 AP		08/04/17	0393028	LADAGE, ZACH		131.04	06/24/20	
VOID-CHECK LOST						RMB:MEALS-BASIC SRO SCHL.				
ACCOUNT TOTAL							.00	145.56	145.56-	
101-6613-433.85-01 UTILITIES / UTILITIES										
2174		12/20 AP		06/15/20	0394633	CEDAR FALLS UTILITIES	65.79		07/01/20	
UTILITIES THRU 06/15/20										
2108		12/20 AP		06/01/20	0394597	CEDAR FALLS UTILITIES	184.37		06/19/20	
UTILITIES THRU 06/01/20										
ACCOUNT TOTAL							250.16	.00	250.16	
101-6616-446.85-01 UTILITIES / UTILITIES										
2174		12/20 AP		06/15/20	0394633	CEDAR FALLS UTILITIES	1,975.86		07/01/20	
UTILITIES THRU 06/15/20										
2108		12/20 AP		06/01/20	0394597	CEDAR FALLS UTILITIES	3,267.64		06/19/20	
UTILITIES THRU 06/01/20										
ACCOUNT TOTAL							5,243.50	.00	5,243.50	

GROUP NBR	PO NBR	ACCTG PER.	CD	---TRANSACTION--- DATE	NUMBER	DESCRIPTION	DEBITS	CREDITS	CURRENT BALANCE POST DT
FUND 101 GENERAL FUND									
101-6623-423.85-01 UTILITIES / UTILITIES									
2174		12/20 AP		06/15/20	0394633	CEDAR FALLS UTILITIES	308.50		07/01/20
						UTILITIES THRU 06/15/20			
2108		12/20 AP		06/01/20	0394597	CEDAR FALLS UTILITIES	721.36		06/19/20
						UTILITIES THRU 06/01/20			
						ACCOUNT TOTAL	1,029.86	.00	1,029.86
101-6633-423.85-01 UTILITIES / UTILITIES									
2174		12/20 AP		06/15/20	0394633	CEDAR FALLS UTILITIES	132.19		07/01/20
						UTILITIES THRU 06/15/20			
2108		12/20 AP		06/01/20	0394597	CEDAR FALLS UTILITIES	1,334.52		06/19/20
						UTILITIES THRU 06/01/20			
						ACCOUNT TOTAL	1,466.71	.00	1,466.71
						FUND TOTAL	118,869.80	2,564.64	116,305.16
FUND 203 TAX INCREMENT FINANCING									
FUND 206 STREET CONSTRUCTION FUND									
206-6637-436.72-56 OPERATING SUPPLIES / FLOOD CONTROL									
2108		12/20 AP		06/01/20	0394597	CEDAR FALLS UTILITIES	111.68		06/19/20
						UTILITIES THRU 06/01/20			
						ACCOUNT TOTAL	111.68	.00	111.68
206-6637-436.85-01 UTILITIES / UTILITIES									
2108		12/20 AP		06/01/20	0394597	CEDAR FALLS UTILITIES	279.00		06/19/20
						UTILITIES THRU 06/01/20			
						ACCOUNT TOTAL	279.00	.00	279.00
206-6647-436.85-01 UTILITIES / UTILITIES									
2174		12/20 AP		06/15/20	0394633	CEDAR FALLS UTILITIES	649.07		07/01/20
						UTILITIES THRU 06/15/20			
2108		12/20 AP		06/01/20	0394597	CEDAR FALLS UTILITIES	998.89		06/19/20
						UTILITIES THRU 06/01/20			
						ACCOUNT TOTAL	1,647.96	.00	1,647.96
						FUND TOTAL	2,038.64	.00	2,038.64

GROUP NBR	PO NBR	ACCTG PER.	CD	---TRANSACTION---	DATE	NUMBER	DESCRIPTION	DEBITS	CREDITS	CURRENT BALANCE	POST DT

FUND 215 HOSPITAL FUND											
FUND 216 POLICE BLOCK GRANT FUND											
FUND 217 SECTION 8 HOUSING FUND											
217-2214-432	89-61	MISCELLANEOUS SERVICES / HOUS.ASSIST PMTS-OCCUPIED									
2129		12/20	AP	06/01/20	0036760		KREMER PROPERTIES LLC		810.00		06/24/20
							VOID CHECK-NOT NEEDED				
16		01/21	AP	07/01/20	0036796		BAUCH, JAMES C	702.00			06/30/20
							HAP_Prior D 072020				
16		01/21	AP	07/01/20	0036840		METROPOLITAN COUNCIL - HRA	447.00			06/30/20
							HAP_McCalister R 072020				
16		01/21	AP	07/01/20	0036849		RINNELS, DOUGLAS G.	256.00			06/30/20
							HAP_Woock J 072020				
16		01/21	AP	07/01/20	0036849		RINNELS, DOUGLAS G.	277.00			06/30/20
							HAP_Wierck L 072020				
16		01/21	AP	07/01/20	0036800		CHESTNUT, SHAWN	439.00			06/30/20
							HAP_Chestnut N 072020				
16		01/21	AP	07/01/20	0036860		WEVERINK, TOM	1,150.00			06/30/20
							HAP_Archer A 072020				
16		01/21	AP	07/01/20	0036860		WEVERINK, TOM	497.00			06/30/20
							HAP_Stewart J 072020				
16		01/21	AP	07/01/20	0036843		OLSON & ESTATES LLC	397.00			06/30/20
							HAP_Graves D 072020				
16		01/21	AP	07/01/20	0036843		OLSON & ESTATES LLC	410.00			06/30/20
							HAP_Weaver J 072020				
16		01/21	AP	07/01/20	0036843		OLSON & ESTATES LLC	437.00			06/30/20
							HAP_Bakel P 072020				
16		01/21	AP	07/01/20	0036843		OLSON & ESTATES LLC	364.00			06/30/20
							HAP_Himes G 072020				
16		01/21	AP	07/01/20	0036843		OLSON & ESTATES LLC	399.00			06/30/20
							HAP_Halterman A 072020				
16		01/21	AP	07/01/20	0036843		OLSON & ESTATES LLC	210.00			06/30/20
							HAP_Stevens B 072020				
16		01/21	AP	07/01/20	0036843		OLSON & ESTATES LLC	381.00			06/30/20
							HAP_Hepker D 072020				
16		01/21	AP	07/01/20	0036813		EXCEPTIONAL PERSONS, INC.	410.00			06/30/20
							HAP_Nissen A 072020				
16		01/21	AP	07/01/20	0036813		EXCEPTIONAL PERSONS, INC.	431.00			06/30/20
							HAP_Myers J 072020				
16		01/21	AP	07/01/20	0036813		EXCEPTIONAL PERSONS, INC.	358.00			06/30/20
							HAP_Poldberg J 072020				
16		01/21	AP	07/01/20	0036813		EXCEPTIONAL PERSONS, INC.	437.00			06/30/20
							HAP_Holmes C 072020				
16		01/21	AP	07/01/20	0036813		EXCEPTIONAL PERSONS, INC.	436.00			06/30/20
							HAP_Blake M 072020				
16		01/21	AP	07/01/20	0036813		EXCEPTIONAL PERSONS, INC.	425.00			06/30/20
							HAP_Easterling R 072020				
16		01/21	AP	07/01/20	0036813		EXCEPTIONAL PERSONS, INC.	158.00			06/30/20
							HAP_Lutz W 072020				
16		01/21	AP	07/01/20	0036820		GOLD FALLS VILLA	423.00			06/30/20
							HAP_Jenkins D 072020				
16		01/21	AP	07/01/20	0036820		GOLD FALLS VILLA	462.00			06/30/20

GROUP NBR	PO NBR	ACCTG PER.	CD	DATE	TRANSACTION NUMBER	DESCRIPTION	DEBITS	CREDITS	CURRENT BALANCE	POST DT
FUND 217 SECTION 8 HOUSING FUND										
217-2214-432.89-61 MISCELLANEOUS SERVICES / HOUS.ASSIST PMTS-OCCUPIED continued										
						HAP_Shuman J 072020				
16		01/21 AP		07/01/20	0036815	FORTSCH, ALEX E.	1,000.00			06/30/20
						HAP_Guzzle T 072020				
16		01/21 AP		07/01/20	0036859	WEVERINK, RANDY	177.00			06/30/20
						HAP_Janssen M 072020				
16		01/21 AP		07/01/20	0036817	GEEELAN, JOSEPH N.	233.00			06/30/20
						HAP_Becker T 072020				
16		01/21 AP		07/01/20	0036817	GEEELAN, JOSEPH N.	372.00			06/30/20
						HAP_Juhl A 072020				
16		01/21 AP		07/01/20	0036802	CLARK ENTERPRISES LLC	191.00			06/30/20
						HAP_Bachman K 072020				
16		01/21 AP		07/01/20	0036802	CLARK ENTERPRISES LLC	520.00			06/30/20
						HAP_Galvez Munguia 072020				
16		01/21 AP		07/01/20	0036802	CLARK ENTERPRISES LLC	261.00			06/30/20
						HAP_Taylor T 072020				
16		01/21 AP		07/01/20	0036802	CLARK ENTERPRISES LLC	144.00			06/30/20
						HAP_Grage K 072020				
16		01/21 AP		07/01/20	0036802	CLARK ENTERPRISES LLC	537.00			06/30/20
						HAP_Hord B 072020				
16		01/21 AP		07/01/20	0036802	CLARK ENTERPRISES LLC	214.00			06/30/20
						HAP_Cook A 072020				
16		01/21 AP		07/01/20	0036821	GRAY, LEROY L. OR CAROLYN K.	650.00			06/30/20
						HAP_Jenkins D 072020				
16		01/21 AP		07/01/20	0036794	BARTELT PROPERTIES L.C.	1,100.00			06/30/20
						HAP_Avino G 072020				
16		01/21 AP		07/01/20	0036794	BARTELT PROPERTIES L.C.	437.00			06/30/20
						HAP_Gebremedhin A 072020				
16		01/21 AP		07/01/20	0036794	BARTELT PROPERTIES L.C.	221.00			06/30/20
						HAP_Cobb R 072020				
16		01/21 AP		07/01/20	0036794	BARTELT PROPERTIES L.C.	689.00			06/30/20
						HAP_Woodward C 072020				
16		01/21 AP		07/01/20	0036809	EDGE MANAGEMENT GROUP, LLC	674.00			06/30/20
						HAP_Young C 072020				
16		01/21 AP		07/01/20	0036809	EDGE MANAGEMENT GROUP, LLC	946.00			06/30/20
						HAP_Gibson T 072020				
16		01/21 AP		07/01/20	0036803	COOK CO.HOUSING AUTHORITY	319.00			06/30/20
						HAP_Goldstein K 072020				
16		01/21 AP		07/01/20	0036848	PURDY PROPERTIES, LLC	720.00			06/30/20
						HAP_Schmidt D 072020				
16		01/21 AP		07/01/20	0036848	PURDY PROPERTIES, LLC	950.00			06/30/20
						HAP_Cummings A 072020				
16		01/21 AP		07/01/20	0036848	PURDY PROPERTIES, LLC	631.00			06/30/20
						HAP_Leiss L 072020				
16		01/21 AP		07/01/20	0036807	D & J PROPERTIES	304.00			06/30/20
						HAP_Bell M 072020				
16		01/21 AP		07/01/20	0036807	D & J PROPERTIES	503.00			06/30/20
						HAP_Grant F 072020				
16		01/21 AP		07/01/20	0036807	D & J PROPERTIES	455.00			06/30/20
						HAP_Terry M 072020				

GROUP	PO	ACCTG	----TRANSACTION----				DEBITS	CREDITS	CURRENT
NBR	NBR	PER.	CD	DATE	NUMBER	DESCRIPTION			BALANCE
									POST DT
FUND 217 SECTION 8 HOUSING FUND									
217-2214-432.89-61 MISCELLANEOUS SERVICES / HOUS.ASSIST PMTS-OCCUPIED						continued			
16		01/21	AP	07/01/20	0036811	EMAAD, LLC	600.00		06/30/20
		HAP_Delauney C 072020							
16		01/21	AP	07/01/20	0036806	CV PROPERTIES, LLC	295.00		06/30/20
		HAP_Barr G 072020							
16		01/21	AP	07/01/20	0036853	STANDARD FAMILY ASSIST.LIVING	162.00		06/30/20
		HAP_REFSHAUGE T 072020							
16		01/21	AP	07/01/20	0036798	CEDAR APARTMENTS LLC	195.00		06/30/20
		HAP_Becerra C 072020							
16		01/21	AP	07/01/20	0036798	CEDAR APARTMENTS LLC	155.00		06/30/20
		HAP_Groskurth D 072020							
16		01/21	AP	07/01/20	0036824	HAUS TO HOME INVESTMENTS	596.00		06/30/20
		HAP_Lehr B 072020							
16		01/21	AP	07/01/20	0036834	KYLER, DEBRA K.	577.00		06/30/20
		HAP_Mussman C 072020							
16		01/21	AP	07/01/20	0036851	SCHUERMAN PROPERTIES, LLC	823.00		06/30/20
		HAP_Jurries P 072020							
16		01/21	AP	07/01/20	0036851	SCHUERMAN PROPERTIES, LLC	895.00		06/30/20
		HAP_Boehmer R 072020							
16		01/21	AP	07/01/20	0036854	SWEETING, LARRY	612.00		06/30/20
		HAP_Schumacher D 072020							
16		01/21	AP	07/01/20	0036856	THUNDER RIDGE SR.APARTMENTS L	133.00		06/30/20
		HAP_Youngberg L 072020							
16		01/21	AP	07/01/20	0036856	THUNDER RIDGE SR.APARTMENTS L	197.00		06/30/20
		HAP_Vognsen P 072020							
16		01/21	AP	07/01/20	0036856	THUNDER RIDGE SR.APARTMENTS L	129.00		06/30/20
		HAP_Garvis C 072020							
16		01/21	AP	07/01/20	0036856	THUNDER RIDGE SR.APARTMENTS L	386.00		06/30/20
		HAP_Good S 072020							
16		01/21	AP	07/01/20	0036856	THUNDER RIDGE SR.APARTMENTS L	336.00		06/30/20
		HAP_Ford M 072020							
16		01/21	AP	07/01/20	0036856	THUNDER RIDGE SR.APARTMENTS L	403.00		06/30/20
		HAP_Toms L 072020							
16		01/21	AP	07/01/20	0036856	THUNDER RIDGE SR.APARTMENTS L	181.00		06/30/20
		HAP_Derifield S 072020							
16		01/21	AP	07/01/20	0036856	THUNDER RIDGE SR.APARTMENTS L	427.00		06/30/20
		HAP_Turner S 072020							
16		01/21	AP	07/01/20	0036856	THUNDER RIDGE SR.APARTMENTS L	485.00		06/30/20
		HAP_Henning S 072020							
16		01/21	AP	07/01/20	0036856	THUNDER RIDGE SR.APARTMENTS L	391.00		06/30/20
		HAP_Lebahn B 072020							
16		01/21	AP	07/01/20	0036856	THUNDER RIDGE SR.APARTMENTS L	212.00		06/30/20
		HAP_Martin H 072020							
16		01/21	AP	07/01/20	0036856	THUNDER RIDGE SR.APARTMENTS L	401.00		06/30/20
		HAP_Strickland L 072020							
16		01/21	AP	07/01/20	0036856	THUNDER RIDGE SR.APARTMENTS L	196.00		06/30/20
		HAP_Matthias L 072020							
16		01/21	AP	07/01/20	0036856	THUNDER RIDGE SR.APARTMENTS L	467.00		06/30/20
		HAP_Hoth P 072020							
16		01/21	AP	07/01/20	0036856	THUNDER RIDGE SR.APARTMENTS L	228.00		06/30/20

GROUP NBR	PO NBR	ACCTG PER.	CD	DATE	TRANSACTION NUMBER	DESCRIPTION	DEBITS	CREDITS	CURRENT BALANCE	POST DT
FUND 217 SECTION 8 HOUSING FUND										
217-2214-432.89-61 MISCELLANEOUS SERVICES / HOUS.ASSIST PMTS-OCCUPIED										
						continued				
16					HAP_Stock M 072020					
				01/21	AP 07/01/20 0036856	THUNDER RIDGE SR.APARTMENTS L	402.00			06/30/20
16					HAP_Stegen R 072020					
				01/21	AP 07/01/20 0036856	THUNDER RIDGE SR.APARTMENTS L	479.00			06/30/20
16					HAP_Howe J 072020					
				01/21	AP 07/01/20 0036856	THUNDER RIDGE SR.APARTMENTS L	206.00			06/30/20
16					HAP_Schlueter J 072020					
				01/21	AP 07/01/20 0036856	THUNDER RIDGE SR.APARTMENTS L	363.00			06/30/20
16					HAP_Tiller R 072020					
				01/21	AP 07/01/20 0036856	THUNDER RIDGE SR.APARTMENTS L	182.00			06/30/20
16					HAP_Wray M 072020					
				01/21	AP 07/01/20 0036856	THUNDER RIDGE SR.APARTMENTS L	361.00			06/30/20
16					HAP_Hayden J 072020					
				01/21	AP 07/01/20 0036856	THUNDER RIDGE SR.APARTMENTS L	410.00			06/30/20
16					HAP_Greene L 072020					
				01/21	AP 07/01/20 0036819	GLENN, MATTHEW	285.00			06/30/20
16					HAP_Clayton R 072020					
				01/21	AP 07/01/20 0036857	VILLAGE I AT NINE23 APARTMENT	402.00			06/30/20
16					HAP_Smith W 072020					
				01/21	AP 07/01/20 0036857	VILLAGE I AT NINE23 APARTMENT	404.00			06/30/20
16					HAP_Aswegan S 072020					
				01/21	AP 07/01/20 0036857	VILLAGE I AT NINE23 APARTMENT	407.00			06/30/20
16					HAP_Swartley J 072020					
				01/21	AP 07/01/20 0036857	VILLAGE I AT NINE23 APARTMENT	119.00			06/30/20
16					HAP_Prior A 072020					
				01/21	AP 07/01/20 0036857	VILLAGE I AT NINE23 APARTMENT	574.00			06/30/20
16					HAP_Ducharme T 072020					
				01/21	AP 07/01/20 0036857	VILLAGE I AT NINE23 APARTMENT	337.00			06/30/20
16					HAP_Cameron J 072020					
				01/21	AP 07/01/20 0036857	VILLAGE I AT NINE23 APARTMENT	432.00			06/30/20
16					HAP_Moore D 072020					
				01/21	AP 07/01/20 0036857	VILLAGE I AT NINE23 APARTMENT	432.00			06/30/20
16					HAP_Brandt D 072020					
				01/21	AP 07/01/20 0036857	VILLAGE I AT NINE23 APARTMENT	337.00			06/30/20
16					HAP_Greene D 072020					
				01/21	AP 07/01/20 0036857	VILLAGE I AT NINE23 APARTMENT	413.00			06/30/20
16					HAP_Porter J 072020					
				01/21	AP 07/01/20 0036857	VILLAGE I AT NINE23 APARTMENT	92.00			06/30/20
16					HAP_Dixon S 072020					
				01/21	AP 07/01/20 0036857	VILLAGE I AT NINE23 APARTMENT	577.00			06/30/20
16					HAP_Hernandez Serr 072020					
				01/21	AP 07/01/20 0036857	VILLAGE I AT NINE23 APARTMENT	275.00			06/30/20
16					HAP_WILLIAMS B 072020					
				01/21	AP 07/01/20 0036857	VILLAGE I AT NINE23 APARTMENT	259.00			06/30/20
16					HAP_Aswegan J 072020					
				01/21	AP 07/01/20 0036857	VILLAGE I AT NINE23 APARTMENT	363.00			06/30/20
16					HAP_Mosley L 072020					
				01/21	AP 07/01/20 0036857	VILLAGE I AT NINE23 APARTMENT	238.00			06/30/20
16					HAP_Havlik C 072020					

GROUP NBR	PO NBR	ACCTG PER.	CD	DATE	TRANSACTION NUMBER	DESCRIPTION	DEBITS	CREDITS	CURRENT BALANCE	POST DT
FUND 217 SECTION 8 HOUSING FUND										
217-2214-432.89-61 MISCELLANEOUS SERVICES / HOUS.ASSIST PMTS-OCCUPIED							continued			
16		01/21 AP		07/01/20	0036857	VILLAGE I AT NINE23 APARTMENT	420.00			06/30/20
		HAP Temple S 072020								
16		01/21 AP		07/01/20	0036857	VILLAGE I AT NINE23 APARTMENT	499.00			06/30/20
		HAP Clark T 072020								
16		01/21 AP		07/01/20	0036857	VILLAGE I AT NINE23 APARTMENT	399.00			06/30/20
		HAP Gordon Jr. T 072020								
16		01/21 AP		07/01/20	0036857	VILLAGE I AT NINE23 APARTMENT	298.00			06/30/20
		HAP Carter Z 072020								
16		01/21 AP		07/01/20	0036857	VILLAGE I AT NINE23 APARTMENT	461.00			06/30/20
		HAP Redd A 072020								
16		01/21 AP		07/01/20	0036857	VILLAGE I AT NINE23 APARTMENT	292.00			06/30/20
		HAP Mace T 072020								
16		01/21 AP		07/01/20	0036857	VILLAGE I AT NINE23 APARTMENT	428.00			06/30/20
		HAP Smith T 072020								
16		01/21 AP		07/01/20	0036857	VILLAGE I AT NINE23 APARTMENT	179.00			06/30/20
		HAP Vaughn S 072020								
16		01/21 AP		07/01/20	0036857	VILLAGE I AT NINE23 APARTMENT	675.00			06/30/20
		HAP Henderson D 072020								
16		01/21 AP		07/01/20	0036857	VILLAGE I AT NINE23 APARTMENT	686.00			06/30/20
		HAP Gilmore A 072020								
16		01/21 AP		07/01/20	0036857	VILLAGE I AT NINE23 APARTMENT	466.00			06/30/20
		HAP Nelson B 072020								
16		01/21 AP		07/01/20	0036857	VILLAGE I AT NINE23 APARTMENT	539.00			06/30/20
		HAP Fry S 072020								
16		01/21 AP		07/01/20	0036857	VILLAGE I AT NINE23 APARTMENT	501.00			06/30/20
		HAP Prior L 072020								
16		01/21 AP		07/01/20	0036857	VILLAGE I AT NINE23 APARTMENT	138.00			06/30/20
		HAP Duesenberg J 072020								
16		01/21 AP		07/01/20	0036857	VILLAGE I AT NINE23 APARTMENT	261.00			06/30/20
		HAP Ford D 072020								
16		01/21 AP		07/01/20	0036857	VILLAGE I AT NINE23 APARTMENT	662.00			06/30/20
		HAP Ambrose A 072020								
16		01/21 AP		07/01/20	0036857	VILLAGE I AT NINE23 APARTMENT	89.00			06/30/20
		HAP Holub T 072020								
16		01/21 AP		07/01/20	0036799	CEDAR FALLS UTILITIES-SEC.8	4.00			06/30/20
		Mullins 9837918987								
16		01/21 AP		07/01/20	0036799	CEDAR FALLS UTILITIES-SEC.8	47.00			06/30/20
		Guzzle 7174748062								
16		01/21 AP		07/01/20	0036799	CEDAR FALLS UTILITIES-SEC.8	91.00			06/30/20
		Jurries 7681775462								
16		01/21 AP		07/01/20	0036799	CEDAR FALLS UTILITIES-SEC.8	63.00			06/30/20
		Redd 1307731360								
16		01/21 AP		07/01/20	0036799	CEDAR FALLS UTILITIES-SEC.8	21.00			06/30/20
		Porter 1690351502								
16		01/21 AP		07/01/20	0036799	CEDAR FALLS UTILITIES-SEC.8	32.00			06/30/20
		Avino 591464234								
16		01/21 AP		07/01/20	0036799	CEDAR FALLS UTILITIES-SEC.8	132.00			06/30/20
		Schmidt 1315389087								
16		01/21 AP		07/01/20	0036799	CEDAR FALLS UTILITIES-SEC.8	48.00			06/30/20

GROUP NBR	PO NBR	ACCTG PER.	CD	DATE	TRANSACTION NUMBER	DESCRIPTION	DEBITS	CREDITS	CURRENT BALANCE	POST DT
FUND 217 SECTION 8 HOUSING FUND										
217-2214-432.89-61 MISCELLANEOUS SERVICES / HOUS.ASSIST PMTS-OCCUPIED										
						continued				
16					Santiago-Lebron 873567879 01/21 AP 07/01/20 0036799	CEDAR FALLS UTILITIES-SEC.8	136.00			06/30/20
16					Delauney 2110898136 01/21 AP 07/01/20 0036799	CEDAR FALLS UTILITIES-SEC.8	112.00			06/30/20
16					Jones 6467907886 01/21 AP 07/01/20 0036799	CEDAR FALLS UTILITIES-SEC.8	18.00			06/30/20
16					Henderson 9651433829 01/21 AP 07/01/20 0036799	CEDAR FALLS UTILITIES-SEC.8	27.00			06/30/20
16					Lindgren 5732705968 01/21 AP 07/01/20 0036799	CEDAR FALLS UTILITIES-SEC.8	148.00			06/30/20
16					Payne 5852275772 01/21 AP 07/01/20 0036799	CEDAR FALLS UTILITIES-SEC.8	129.00			06/30/20
16					Jenkins 3232058083 01/21 AP 07/01/20 0036799	CEDAR FALLS UTILITIES-SEC.8	112.00			06/30/20
16					Rule 9816666531 01/21 AP 07/01/20 0036799	CEDAR FALLS UTILITIES-SEC.8	55.00			06/30/20
16					Archer 9095290344 01/21 AP 07/01/20 0036799	CEDAR FALLS UTILITIES-SEC.8	78.00			06/30/20
16					Boehmer 08276056267 01/21 AP 07/01/20 0036799	CEDAR FALLS UTILITIES-SEC.8	170.00			06/30/20
16					Cummings 2377106583 01/21 AP 07/01/20 0036801	CHRISTOPHERSON RENTALS	477.00			06/30/20
16					HAP Carlyle T 072020 01/21 AP 07/01/20 0036801	CHRISTOPHERSON RENTALS	299.00			06/30/20
16					HAP Belcher J 072020 01/21 AP 07/01/20 0036801	CHRISTOPHERSON RENTALS	541.00			06/30/20
16					HAP Williams L 072020 01/21 AP 07/01/20 0036801	CHRISTOPHERSON RENTALS	292.00			06/30/20
16					HAP Schwaab A 072020 01/21 AP 07/01/20 0036801	CHRISTOPHERSON RENTALS	472.00			06/30/20
16					HAP Gregory L 072020 01/21 AP 07/01/20 0036801	CHRISTOPHERSON RENTALS	666.00			06/30/20
16					HAP Ricks F 072020 01/21 AP 07/01/20 0036801	CHRISTOPHERSON RENTALS	693.00			06/30/20
16					HAP Hoffert J 072020 01/21 AP 07/01/20 0036801	CHRISTOPHERSON RENTALS	503.00			06/30/20
16					HAP Hunt M 072020 01/21 AP 07/01/20 0036801	CHRISTOPHERSON RENTALS	434.00			06/30/20
16					HAP Thoms A 072020 01/21 AP 07/01/20 0036801	CHRISTOPHERSON RENTALS	499.00			06/30/20
16					HAP Brown D 072020 01/21 AP 07/01/20 0036838	MELICK, KENT L.	598.00			06/30/20
16					HAP Drewelow D 072020 01/21 AP 07/01/20 0036847	PETERSEN, RANDEL	1,165.00			06/30/20
16					HAP Brown S 072020 01/21 AP 07/01/20 0036841	MHP 2216 LINCOLN STREET, LLC	555.00			06/30/20
16					HAP Johnson T 072020 01/21 AP 07/01/20 0036841	MHP 2216 LINCOLN STREET, LLC	417.00			06/30/20
					HAP Wilder S 072020					

GROUP NBR	PO NBR	ACCTG PER.	CD	DATE	TRANSACTION NUMBER	DESCRIPTION	DEBITS	CREDITS	CURRENT BALANCE
									POST DT
FUND 217 SECTION 8 HOUSING FUND									
217-2214-432.89-61 MISCELLANEOUS SERVICES / HOUS.ASSIST PMTS-OCCUPIED						continued			
16		01/21 AP		07/01/20	0036841	MHP 2216 LINCOLN STREET, LLC	525.00		06/30/20
		HAP_Jones T 072020							
16		01/21 AP		07/01/20	0036841	MHP 2216 LINCOLN STREET, LLC	412.00		06/30/20
		HAP_Cochran S 072020							
16		01/21 AP		07/01/20	0036841	MHP 2216 LINCOLN STREET, LLC	423.00		06/30/20
		HAP_Malone S 072020							
16		01/21 AP		07/01/20	0036841	MHP 2216 LINCOLN STREET, LLC	268.00		06/30/20
		HAP_Treslan G 072020							
16		01/21 AP		07/01/20	0036841	MHP 2216 LINCOLN STREET, LLC	525.00		06/30/20
		HAP_Rule S 072020							
16		01/21 AP		07/01/20	0036812	EPM IOWA	556.00		06/30/20
		HAP_Thompson T 072020							
16		01/21 AP		07/01/20	0036812	EPM IOWA	761.00		06/30/20
		HAP_Harkider D 072020							
16		01/21 AP		07/01/20	0036812	EPM IOWA	432.00		06/30/20
		HAP_Frisch K 072020							
16		01/21 AP		07/01/20	0036812	EPM IOWA	1,373.00		06/30/20
		HAP_Santiago-Lebro 072020							
16		01/21 AP		07/01/20	0036812	EPM IOWA	902.00		06/30/20
		HAP_Nicholson K 072020							
16		01/21 AP		07/01/20	0036812	EPM IOWA	381.00		06/30/20
		HAP_Lewis H 072020							
16		01/21 AP		07/01/20	0036812	EPM IOWA	427.00		06/30/20
		HAP_Nobles M 072020							
16		01/21 AP		07/01/20	0036812	EPM IOWA	812.00		06/30/20
		HAP_Gordon A 072020							
16		01/21 AP		07/01/20	0036808	DC MANAGEMENT, LLC	632.00		06/30/20
		HAP_White M 072020							
16		01/21 AP		07/01/20	0036805	CTV MANAGER, LLC	352.00		06/30/20
		HAP_Anderson B 072020							
16		01/21 AP		07/01/20	0036833	KROEMER, KRAIG	417.00		06/30/20
		HAP_Currie L 072020							
16		01/21 AP		07/01/20	0036836	LEGACY RESIDENTIAL	453.00		06/30/20
		HAP_JORDAN L 072020							
16		01/21 AP		07/01/20	0036793	ARENDS INVESTMENTS	266.00		06/30/20
		HAP_Wortham W 072020							
16		01/21 AP		07/01/20	0036844	OWL INVESTMENTS, LLC	507.00		06/30/20
		HAP_Schroeder S 072020							
16		01/21 AP		07/01/20	0036804	CRESCENT CONDOMINIUMS, LLC	435.00		06/30/20
		HAP_Lohr K 072020							
16		01/21 AP		07/01/20	0036823	HARRINGTON'S RENTAL LLC	188.00		06/30/20
		HAP_Larronda E 072020							
16		01/21 AP		07/01/20	0036814	FERNHOLZ, KARI L.	1,220.00		06/30/20
		HAP_Carlton D 072020							
16		01/21 AP		07/01/20	0036850	ROGERS, DERICK	949.00		06/30/20
		HAP_Sherwood J 072020							
16		01/21 AP		07/01/20	0036846	PETERSEN RENTAL PROPERTIES, L	801.00		06/30/20
		HAP_Newsome A 072020							
16		01/21 AP		07/01/20	0036830	KAI, BRENT	283.00		06/30/20

GROUP NBR	PO NBR	ACCTG PER.	CD	DATE	TRANSACTION NUMBER	DESCRIPTION	DEBITS	CREDITS	CURRENT BALANCE	POST DT
FUND 217 SECTION 8 HOUSING FUND										
217-2214-432.89-61 MISCELLANEOUS SERVICES / HOUS.ASSIST PMTS-OCCUPIED continued										
16					HAP_Hamilton T 072020					
				01/21	AP 07/01/20 0036842	MORRIS, RICHARD R.	858.00			06/30/20
					HAP_Sauer M 072020					
16				01/21	AP 07/01/20 0036852	STAND FIRM PROPERTIES LLC	399.00			06/30/20
					HAP_Hodge G 072020					
16				01/21	AP 07/01/20 0036862	WYMORE, LARRY R.	732.00			06/30/20
					HAP_MOFFETT J 072020					
16				01/21	AP 07/01/20 0036828	JDR PROPERTIES, INC.	192.00			06/30/20
					HAP_Klein R 072020					
16				01/21	AP 07/01/20 0036861	WINGSB, LLC	121.00			06/30/20
					HAP_Spiers A 072020					
16				01/21	AP 07/01/20 0036861	WINGSB, LLC	519.00			06/30/20
					HAP_Johnson A 072020					
16				01/21	AP 07/01/20 0036829	JLL EXTENDED STAY INN	302.00			06/30/20
					HAP_Moore E 072020					
16				01/21	AP 07/01/20 0036829	JLL EXTENDED STAY INN	550.00			06/30/20
					HAP_Johnson Y 072020					
16				01/21	AP 07/01/20 0036835	LARSEN RENTALS LLC	234.00			06/30/20
					HAP_Grisby C 072020					
16				01/21	AP 07/01/20 0036858	VILLAGE II AT NINE23 APARTMEN	401.00			06/30/20
					HAP_Lam K 072020					
16				01/21	AP 07/01/20 0036858	VILLAGE II AT NINE23 APARTMEN	401.00			06/30/20
					HAP_Billman D 072020					
16				01/21	AP 07/01/20 0036858	VILLAGE II AT NINE23 APARTMEN	150.00			06/30/20
					HAP_Frazier T 072020					
16				01/21	AP 07/01/20 0036858	VILLAGE II AT NINE23 APARTMEN	432.00			06/30/20
					HAP_Humphrey E 072020					
16				01/21	AP 07/01/20 0036858	VILLAGE II AT NINE23 APARTMEN	675.00			06/30/20
					HAP_Mullins J 072020					
16				01/21	AP 07/01/20 0036858	VILLAGE II AT NINE23 APARTMEN	460.00			06/30/20
					HAP_Garrigus S 072020					
16				01/21	AP 07/01/20 0036858	VILLAGE II AT NINE23 APARTMEN	304.00			06/30/20
					HAP_Wiedow C 072020					
16				01/21	AP 07/01/20 0036858	VILLAGE II AT NINE23 APARTMEN	234.00			06/30/20
					HAP_Baker A 072020					
16				01/21	AP 07/01/20 0036858	VILLAGE II AT NINE23 APARTMEN	407.00			06/30/20
					HAP_Harrenstein G 072020					
16				01/21	AP 07/01/20 0036858	VILLAGE II AT NINE23 APARTMEN	378.00			06/30/20
					HAP_BALM D 072020					
16				01/21	AP 07/01/20 0036858	VILLAGE II AT NINE23 APARTMEN	87.00			06/30/20
					HAP_Hoodjer S 072020					
16				01/21	AP 07/01/20 0036858	VILLAGE II AT NINE23 APARTMEN	700.00			06/30/20
					HAP_Redd S 072020					
16				01/21	AP 07/01/20 0036858	VILLAGE II AT NINE23 APARTMEN	200.00			06/30/20
					HAP_Forney A 072020					
16				01/21	AP 07/01/20 0036858	VILLAGE II AT NINE23 APARTMEN	412.00			06/30/20
					HAP_Haug K 072020					
16				01/21	AP 07/01/20 0036858	VILLAGE II AT NINE23 APARTMEN	376.00			06/30/20
					HAP_Saccento J 072020					

GROUP NBR	PO NBR	ACCTG PER.	CD	DATE	TRANSACTION NUMBER	DESCRIPTION	DEBITS	CREDITS	CURRENT BALANCE
									POST DT
FUND 217 SECTION 8 HOUSING FUND									
217-2214-432.89-61 MISCELLANEOUS SERVICES / HOUS.ASSIST PMTS-OCCUPIED						continued			
16		01/21 AP		07/01/20	0036858	VILLAGE II AT NINE23 APARTMEN	428.00		06/30/20
		HAP Loffredo C 072020							
16		01/21 AP		07/01/20	0036858	VILLAGE II AT NINE23 APARTMEN	530.00		06/30/20
		HAP Brown S 072020							
16		01/21 AP		07/01/20	0036858	VILLAGE II AT NINE23 APARTMEN	652.00		06/30/20
		HAP Miller K 072020							
16		01/21 AP		07/01/20	0036858	VILLAGE II AT NINE23 APARTMEN	481.00		06/30/20
		HAP Humphrey J 072020							
16		01/21 AP		07/01/20	0036858	VILLAGE II AT NINE23 APARTMEN	328.00		06/30/20
		HAP Dzapo S 072020							
16		01/21 AP		07/01/20	0036858	VILLAGE II AT NINE23 APARTMEN	428.00		06/30/20
		HAP Harken G 072020							
16		01/21 AP		07/01/20	0036858	VILLAGE II AT NINE23 APARTMEN	332.00		06/30/20
		HAP Harmon A 072020							
16		01/21 AP		07/01/20	0036858	VILLAGE II AT NINE23 APARTMEN	339.00		06/30/20
		HAP Wilson J 072020							
16		01/21 AP		07/01/20	0036858	VILLAGE II AT NINE23 APARTMEN	630.00		06/30/20
		HAP Wilson S 072020							
16		01/21 AP		07/01/20	0036858	VILLAGE II AT NINE23 APARTMEN	556.00		06/30/20
		HAP Cruise B 072020							
16		01/21 AP		07/01/20	0036858	VILLAGE II AT NINE23 APARTMEN	236.00		06/30/20
		HAP King D 072020							
16		01/21 AP		07/01/20	0036858	VILLAGE II AT NINE23 APARTMEN	513.00		06/30/20
		HAP Reams L 072020							
16		01/21 AP		07/01/20	0036858	VILLAGE II AT NINE23 APARTMEN	498.00		06/30/20
		HAP Nielsen J 072020							
16		01/21 AP		07/01/20	0036858	VILLAGE II AT NINE23 APARTMEN	264.00		06/30/20
		HAP O'dell J 072020							
16		01/21 AP		07/01/20	0036858	VILLAGE II AT NINE23 APARTMEN	139.00		06/30/20
		HAP Rogers E 072020							
16		01/21 AP		07/01/20	0036858	VILLAGE II AT NINE23 APARTMEN	452.00		06/30/20
		HAP OBrien N 072020							
16		01/21 AP		07/01/20	0036858	VILLAGE II AT NINE23 APARTMEN	304.00		06/30/20
		HAP Sommerfelt C 072020							
16		01/21 AP		07/01/20	0036831	KLEIN, JULIE	152.00		06/30/20
		HAP Stover A 072020							
16		01/21 AP		07/01/20	0036825	HOUSING AUTHORITY OF JOLIET	993.00		06/30/20
		HAP Wilson Q 072020							
16		01/21 AP		07/01/20	0036826	HOWARD, BRAD	324.00		06/30/20
		HAP Thrower M 072020							
16		01/21 AP		07/01/20	0036839	MESQUITE HOUSING OFFICE	1,634.00		06/30/20
		HAP Moore S 072020							
16		01/21 AP		07/01/20	0036832	KREMER PROPERTIES LLC	791.00		06/30/20
		HAP Mulanax W 072020							
16		01/21 AP		07/01/20	0036822	HANSON, KALEEN KIRCHNER	1,200.00		06/30/20
		HAP Payne I 072020							
16		01/21 AP		07/01/20	0036845	PAULSON, JAMES	354.00		06/30/20
		HAP Topping R 072020							
16		01/21 AP		07/01/20	0036845	PAULSON, JAMES	156.00		06/30/20

GROUP NBR	PO NBR	ACCTG PER.	CD	DATE	TRANSACTION NUMBER	DESCRIPTION	DEBITS	CREDITS	CURRENT BALANCE	POST DT
FUND 217 SECTION 8 HOUSING FUND										
217-2214-432.89-61 MISCELLANEOUS SERVICES / HOUS.ASSIST PMTS-OCCUPIED continued										
					HAP_Gordon L 072020					
16		01/21 AP		07/01/20	0036810	ELMCREST ESTATES, L.C.	587.00			06/30/20
					HAP_Davis D 072020					
16		01/21 AP		07/01/20	0036837	MCKERNAN, JAMES M.	725.00			06/30/20
					HAP_Porter R 072020					
16		01/21 AP		07/01/20	0036837	MCKERNAN, JAMES M.	492.00			06/30/20
					HAP_Buchanan J 072020					
16		01/21 AP		07/01/20	0036816	G P MANAGEMENT LLC	406.00			06/30/20
					HAP_Wenzel J 072020					
16		01/21 AP		07/01/20	0036855	T.J.J.C. L.L.C.	282.00			06/30/20
					HAP_Dornbrock M 072020					
16		01/21 AP		07/01/20	0036855	T.J.J.C. L.L.C.	176.00			06/30/20
					HAP_Hornback K 072020					
16		01/21 AP		07/01/20	0036818	GERDES III, BENJAMIN P.	283.00			06/30/20
					HAP_Allessi S 072020					
16		01/21 AP		07/01/20	0036818	GERDES III, BENJAMIN P.	700.00			06/30/20
					HAP_Lindgren T 072020					
16		01/21 AP		07/01/20	0036818	GERDES III, BENJAMIN P.	328.00			06/30/20
					HAP_Johnson C 072020					
16		01/21 AP		07/01/20	0036818	GERDES III, BENJAMIN P.	722.00			06/30/20
					HAP_Apfel A 072020					
16		01/21 AP		07/01/20	0036818	GERDES III, BENJAMIN P.	603.00			06/30/20
					HAP_Beaman D 072020					
16		01/21 AP		07/01/20	0036818	GERDES III, BENJAMIN P.	618.00			06/30/20
					HAP_Sherwood D 072020					
16		01/21 AP		07/01/20	0036827	J & A PROPERTIES	1,058.00			06/30/20
					HAP_Bailey N 072020					
16		01/21 AP		07/01/20	0036795	BARTELT RENTALS L.C.	385.00			06/30/20
					HAP_Luck J 072020					
16		01/21 AP		07/01/20	0036795	BARTELT RENTALS L.C.	976.00			06/30/20
					HAP_Woods N 072020					
16		01/21 AP		07/01/20	0036797	C & H HOLDINGS LLC	566.00			06/30/20
					HAP_Ross S 072020					
ACCOUNT TOTAL							101,457.00	810.00		100,647.00
217-2214-432.89-65 MISCELLANEOUS SERVICES / ADMIN FEE DUE OTHERS										
16		01/21 AP		07/01/20	0036840	METROPOLITAN COUNCIL - HRA	45.73			06/30/20
					AF_McCalister R 072020					
16		01/21 AP		07/01/20	0036803	COOK CO.HOUSING AUTHORITY	34.16			06/30/20
					AF_Goldstein K 072020					
16		01/21 AP		07/01/20	0036825	HOUSING AUTHORITY OF JOLIET	45.73			06/30/20
					AF_Wilson Q 072020					
16		01/21 AP		07/01/20	0036839	MESQUITE HOUSING OFFICE	57.16			06/30/20
					AF_Moore S 072020					
ACCOUNT TOTAL							182.78	0.00		182.78

GROUP NBR	PO NBR	ACCTG PER.	CD	DATE	TRANSACTION NUMBER	DESCRIPTION	DEBITS	CREDITS	CURRENT BALANCE	POST DT
FUND 217 SECTION 8 HOUSING FUND										
FUND TOTAL							101,639.78	810.00	100,829.78	
FUND 223 COMMUNITY BLOCK GRANT										
FUND 224 TRUST & AGENCY										
FUND 242 STREET REPAIR FUND										
FUND 254 CABLE TV FUND										
254-1088-431.89-18 MISCELLANEOUS SERVICES / COMMUNITY PROGRAMMING										
2156		12/20 AP		06/25/20	0394628	STOW, CHRISTIAN CAMERA OPERATOR	85.00			06/29/20
PROJECT#: 759										
2156		12/20 AP		06/25/20	0394624	DEWITT, JASON CAMERA OPERATOR	85.00			06/29/20
PROJECT#: 759										
2156		12/20 AP		06/25/20	0394629	SURMA, JOSEPH EDWARD CAMERA OPERATOR	85.00			06/29/20
PROJECT#: 759										
2156		12/20 AP		06/25/20	0394623	BENSON, ERIC CAMERA OPERATOR	85.00			06/29/20
PROJECT#: 759										
2156		12/20 AP		06/25/20	0394627	SIMPSON, MARK ANNOUNCER	120.00			06/29/20
PROJECT#: 759										
2156		12/20 AP		06/25/20	0394626	JOACHIM, JOHN D ANNOUNCER	100.00			06/29/20
PROJECT#: 759										
2137		12/20 AP		06/23/20	0394620	SIMPSON, MARK ANNOUNCER	120.00			06/25/20
PROJECT#: 759										
2137		12/20 AP		06/23/20	0394619	JOACHIM, JOHN D ANNOUNCER	100.00			06/25/20
PROJECT#: 759										
2137		12/20 AP		06/23/20	0394616	DEWITT, JASON CAMERA OPERATOR	85.00			06/25/20
PROJECT#: 759										
2137		12/20 AP		06/23/20	0394621	STOW, CHRISTIAN CAMERA OPERATOR	85.00			06/25/20
PROJECT#: 759										
2137		12/20 AP		06/23/20	0394614	BENSON, ERIC CAMERA OPERATOR	85.00			06/25/20
PROJECT#: 759										
2137		12/20 AP		06/23/20	0394622	SURMA, JOSEPH EDWARD CAMERA OPERATOR	85.00			06/25/20
PROJECT#: 759										
2108		12/20 AP		06/16/20	0394598	DEWITT, JASON CAMERA OPERATOR	105.00			06/19/20
PROJECT#: 759										
2108		12/20 AP		06/16/20	0394604	SIMPSON, MARK ANNOUNCER	120.00			06/19/20
PROJECT#: 759										

GROUP NBR	PO NBR	ACCTG PER.	CD	DATE	NUMBER	DESCRIPTION	DEBITS	CREDITS	CURRENT BALANCE
									POST DT
FUND 254 CABLE TV FUND									
254-1088-431.89-18 MISCELLANEOUS SERVICES / COMMUNITY PROGRAMMING						continued			
2108		12/20 AP		06/16/20	0394599	LONGNECKER, JEREMIAH CF BASEBALL-W'LOO WEST ANNOUNCER	120.00		06/19/20
PROJECT#:		759							
2119		12/20 AP		06/16/20	0394608	STOW, CHRISTIAN CF BASEBALL-WATERLOO WEST CAMERA OPERATOR	105.00		06/23/20
PROJECT#:		759							
2119		12/20 AP		06/16/20	0394609	SURMA, JOSEPH EDWARD CF BASEBALL-WATERLOO WEST CAMERA OPERATOR	105.00		06/23/20
PROJECT#:		759							
2119		12/20 AP		06/16/20	0394605	BENSON, ERIC CF BASEBALL-WATERLOO WEST CAMERA OPERATOR	105.00		06/23/20
PROJECT#:		759							
ACCOUNT TOTAL							1,780.00	0.00	1,780.00
FUND TOTAL							1,780.00	0.00	1,780.00
FUND 258 PARKING FUND									
258-5531-435.86-01 REPAIR & MAINTENANCE / REPAIR & MAINTENANCE									
2108		12/20 AP		06/01/20	0394597	CEDAR FALLS UTILITIES UTILITIES THRU 06/01/20	15.75		06/19/20
ACCOUNT TOTAL							15.75	0.00	15.75
FUND TOTAL							15.75	0.00	15.75
FUND 261 TOURISM & VISITORS									
261-2291-423.72-01 OPERATING SUPPLIES / OPERATING SUPPLIES									
2108		12/20 AP		05/18/20	0394600	MANNING, KIM RMB:BATTERY-CAR REMOTE	5.97		06/19/20
ACCOUNT TOTAL							5.97	0.00	5.97
261-2291-423.85-01 UTILITIES / UTILITIES									
2174		12/20 AP		06/15/20	0394633	CEDAR FALLS UTILITIES UTILITIES THRU 06/15/20	69.27		07/01/20
ACCOUNT TOTAL							69.27	0.00	69.27
FUND TOTAL							75.24	0.00	75.24

GROUP NBR	PO NBR	ACCTG PER.	CD	DATE	---TRANSACTION--- NUMBER	DESCRIPTION	DEBITS	CREDITS	CURRENT BALANCE POST DT ----
FUND 262 SENIOR SERVICES & COMM CT									
262-1092-423.85-01 UTILITIES / UTILITIES									
2071		12/20 AP		06/05/20	0000000	CEDAR FALLS UTILITIES	423.58		06/26/20
2108		12/20 AP		06/01/20	0394597	CEDAR FALLS UTILITIES COMMUNITY CNTER UTILITIES UTILITIES THRU 06/01/20	99.05		06/19/20
ACCOUNT TOTAL							522.63	.00	522.63
262-1092-423.87-01 RENTALS / RENTALS									
2137		12/20 AP		06/22/20	0394617	HEIDI SEEGERS	250.00		06/25/20
2085		12/20 AP		06/12/20	0394590	TINA FORD REFUND-SECURITY DEPOSIT REFUND-SECURITY DEPOSIT CITY BUILDINGS CLOSED	430.00		06/17/20
ACCOUNT TOTAL							680.00	.00	680.00
FUND TOTAL							1,202.63	.00	1,202.63
FUND 291 POLICE FORFEITURE FUND									
291-5521-415.89-41 MISCELLANEOUS SERVICES / POLICE EQUIPMENT									
2108		12/20 AP		06/18/20	0394594	BLACK HAWK CO.ATTORNEY	17.50		06/19/20
2108		12/20 AP		06/18/20	0394602	PROSECUTING ATTORNEYS BRYCE HINDERS FORFEITURE	17.50		06/19/20
2108		12/20 AP		06/18/20	0394603	PROSECUTING ATTORNEYS BRYCE HINDERS FORFEITURE	449.49		06/19/20
2108		12/20 AP		06/18/20	0394595	BLACK HAWK CO.ATTORNEY J. BLAKELY FORFEITURE J. BLAKELY FORFEITURE	449.49		06/19/20
ACCOUNT TOTAL							933.98	.00	933.98
FUND TOTAL							933.98	.00	933.98
FUND 292 POLICE RETIREMENT FUND									
FUND 293 FIRE RETIREMENT FUND									
FUND 294 LIBRARY RESERVE									
FUND 295 SOFTBALL PLAYER CAPITAL									
FUND 296 GOLF CAPITAL									
FUND 297 REC FACILITIES CAPITAL									
FUND 298 HEARST CAPITAL									

GROUP	PO	ACCTG	-----TRANSACTION-----				DEBITS	CREDITS	CURRENT
NBR	NBR	PER.	CD	DATE	NUMBER	DESCRIPTION			BALANCE
									POST DT ----
FUND 311	DEBT SERVICE FUND								
FUND 402	WASHINGTON PARK FUND								
FUND 404	FEMA								
FUND 405	FLOOD RESERVE FUND								
FUND 407	VISION IOWA PROJECT								
FUND 408	STREET IMPROVEMENT FUND								
FUND 430	2004 TIF BOND								
FUND 430	2004 TIF BOND								
430-1220-431.97-49	ADMINISTRATIVE SERVICES / TIF BOND PROJECTS								
2174	12/20 AP 06/29/20 0394631					BLACK HAWK CO.SHERIFF	576.02		07/01/20
	SHERIFF CONDEMNATION COST					POSTING,POSTAGE,COPIES			
PROJECT#:	023141								
2174	12/20 AP 06/29/20 0394632					BLACK HAWK CO.SHERIFF	1,306.69		07/01/20
	COMMISSIONER'S COSTS								
PROJECT#:	023141								
2174	12/20 AP 06/29/20 0394634					JKC INVESTMENTS, LLC	27,000.00		07/01/20
	NOTATION-DAMAGES								
PROJECT#:	023141								
2174	12/20 AP 06/29/20 0394635					JKC INVESTMENTS, LLC	3,000.00		07/01/20
	NOTATION-ATTORNEY FEES								
PROJECT#:	023141								
	ACCOUNT TOTAL						31,882.71	.00	31,882.71
	FUND TOTAL						31,882.71	.00	31,882.71
FUND 430	2004 TIF BOND								
FUND 431	2014 BOND								
FUND 432	2003 BOND								
FUND 433	2001 TIF								
FUND 434	2000 BOND								
FUND 435	1999 TIF								
FUND 436	2012 BOND								
FUND 437	2018 BOND								
FUND 438	2020 BOND FUND								
FUND 439	2008 BOND FUND								
FUND 443	CAPITAL PROJECTS								
443-1220-431.94-33	CAPITAL PROJECTS / PROPERTY ACQUISITION								
2108	12/20 AP 06/01/20 0394597					CEDAR FALLS UTILITIES	78.59		06/19/20
	UTILITIES THRU 06/01/20								
	ACCOUNT TOTAL						78.59	.00	78.59
	FUND TOTAL						78.59	.00	78.59

GROUP	PO	ACCTG	-----TRANSACTION-----			DESCRIPTION	DEBITS	CREDITS	CURRENT
NBR	NBR	PER.	CD	DATE	NUMBER			BALANCE	
									POST DT
FUND 472									
FUND 473									
FUND 483									
FUND 484									
FUND 541									
FUND 544									
FUND 545									
FUND 546									
FUND 547									
FUND 548									
FUND 549									
FUND 550									
FUND 551									
551-6685-436.85-01 UTILITIES / UTILITIES									
2108		12/20 AP	06/01/20	0394597	CEDAR FALLS UTILITIES	793.96			06/19/20
					UTILITIES THRU 06/01/20				
					ACCOUNT TOTAL	793.96	.00	793.96	
551-6685-436.87-02 RENTALS / MATERIAL DISPOSAL/HANDLIN									
2108		12/20 AP	06/15/20	0394596	BLACK HAWK CO.LANDFILL	23,854.71			06/19/20
					LANDFILL SRV:6/1-6/15/20				
					ACCOUNT TOTAL	23,854.71	.00	23,854.71	
					FUND TOTAL	24,648.67	.00	24,648.67	
FUND 552 SEWER RENTAL FUND									
552-6655-436.85-01 UTILITIES / UTILITIES									
2174		12/20 AP	06/15/20	0394633	CEDAR FALLS UTILITIES	2,834.68			07/01/20
					UTILITIES THRU 06/15/20				
2108		12/20 AP	06/01/20	0394597	CEDAR FALLS UTILITIES	5,040.64			06/19/20
					UTILITIES THRU 06/01/20				
					ACCOUNT TOTAL	7,875.32	.00	7,875.32	
552-6665-436.85-01 UTILITIES / UTILITIES									
2108		12/20 AP	06/01/20	0394597	CEDAR FALLS UTILITIES	11,935.52			06/19/20
					UTILITIES THRU 06/01/20				
					ACCOUNT TOTAL	11,935.52	.00	11,935.52	
552-6665-436.86-33 REPAIR & MAINTENANCE / SLUDGE REMOVAL									
2108		12/20 AP	06/15/20	0394596	BLACK HAWK CO.LANDFILL	259.11			06/19/20
					LANDFILL SRV:6/1-6/15/20				
					ACCOUNT TOTAL	259.11	.00	259.11	

GROUP NBR	PO NBR	ACCTG PER.	CD	TRANSACTION DATE	NUMBER	DESCRIPTION	DEBITS	CREDITS	CURRENT BALANCE	POST DT
FUND 552 SEWER RENTAL FUND										
FUND TOTAL							20,069.95	.00	20,069.95	
FUND 553 2004 SEWER BOND										
FUND 555 STORM WATER UTILITY										
FUND 570 SEWER ASSESSMENT										
FUND 606 DATA PROCESSING FUND										
606-1078-441.81-43						PROFESSIONAL SERVICES / LIBRARY COMPUTER SERVICES				
2085		12/20 AP		06/10/20	0394585	CEDAR FALLS UTILITIES	15.00		06/17/20	
						LIBRARY DOMAIN NAME				
						STATIC IP ADDRESS				
ACCOUNT TOTAL							15.00	.00	15.00	
606-1078-441.82-10 COMMUNICATION / TELEPHONE HOLDING ACCOUNT										
2085		12/20 AP		06/06/20	0394591	U.S. CELLULAR	82.26		06/17/20	
						CELL PHONE:6/6-7/5/20				
2085		12/20 AP		06/06/20	0394592	U.S. CELLULAR	2,376.28		06/17/20	
						WIRELESS SRV:6/6-7/5/20				
ACCOUNT TOTAL							2,458.54	.00	2,458.54	
606-1078-441.82-30 COMMUNICATION / FIBER OPTICS										
2085		12/20 AP		06/10/20	0394585	CEDAR FALLS UTILITIES	3,320.00		06/17/20	
						FIBER POINT:5/11-6/10/20				
ACCOUNT TOTAL							3,320.00	.00	3,320.00	
FUND TOTAL							5,793.54	.00	5,793.54	
FUND 680 HEALTH INSURANCE FUND										
FUND 681 HEALTH SEVERANCE										
681-1902-457.51-10						INSURANCE / HEALTH SEVERANCE PAYMENTS				
2119		12/20 AP		06/22/20	0394606	LUX, JOSH	101.19		06/23/20	
						RMB:HEALTH SEV.1/2 JUN'20				
2068		12/20 AP		06/11/20	0394580	LUX, JOSH	101.19		06/15/20	
						RMB:HEALTH SEV.1/2 MAY'20				
2068		12/20 AP		06/10/20	0394578	ANDERSON, ALETA L.	144.60		06/15/20	
						RMB:MAY 2020 HEALTH SEV.				
2068		12/20 AP		06/10/20	0394578	ANDERSON, ALETA L.	144.60		06/15/20	
						RMB:MAY 2020 HEALTH SEV.				
						MEDICARE-ALETA				
						MEDICARE-RICHARD				
ACCOUNT TOTAL							491.58	.00	491.58	
FUND TOTAL							491.58	.00	491.58	

GROUP NBR	PO NBR	ACCTG PER.	CD	DATE	TRANSACTION NUMBER	DESCRIPTION	DEBITS	CREDITS	CURRENT BALANCE	POST DT
FUND 682 HEALTH INSURANCE - FIRE										
FUND 685 VEHICLE MAINTENANCE FUND										
FUND 686 PAYROLL FUND										
686-0000-222.05-00						PAYROLL LIABILITY / OTHER DEDUCTIONS PAYABLE				
2137		12/20 AP		06/25/20	0394612	ADVANTAGE ADMINISTRATORS	1,168.37			06/25/20
						CAFETERIA PLAN:06/30/20				
2087		12/20 AP		06/17/20	0394584	ADVANTAGE ADMINISTRATORS	6,058.04			06/17/20
						CAFETERIA PLAN:06/19/20				
2087		12/20 AP		06/17/20	0394589	TEAMSTERS LOCAL #238	3,913.72			06/17/20
						UNION DUES-JUNE 2020				
2087		12/20 AP		06/17/20	0394586	CEDAR VALLEY UNITED WAY	40.02			06/17/20
						2ND QTR.2020 CONTRIBUTION				
19		01/21 AP		06/30/20	0394630	ADVANTAGE ADMINISTRATORS	5,806.18			07/01/20
						CAFETERIA PLAN:07/02/20				
						ACCOUNT TOTAL	16,986.33	0.00		16,986.33
						FUND TOTAL	16,986.33	0.00		16,986.33
FUND 687 WORKERS COMPENSATION FUND										
687-1902-457.51-02						INSURANCE / WORKERS COMP INSURANCE				
2128		12/20 AP		03/05/19	0392958	CEDAR VALLEY MEDICAL SPECIALI		1,723.80		06/24/20
						VOID CHECK-PD IN ERROR				
						W/C:K.TEGTMEIER-03/05/19				
						ACCOUNT TOTAL	0.00	1,723.80		1,723.80-
						FUND TOTAL	0.00	1,723.80		1,723.80-
FUND 688 LTD INSURANCE FUND										
688-1902-457.51-04						INSURANCE / LIFE INSURANCE				
19		01/21 AP		07/01/20	0394637	STANDARD INSURANCE COMPANY	3,250.35			07/01/20
						GROUP LIFE AD/D-JUL'20				
						ACCOUNT TOTAL	3,250.35	0.00		3,250.35
						FUND TOTAL	3,250.35	0.00		3,250.35
FUND 689 LIABILITY INSURANCE FUND										
FUND 724 TRUST & AGENCY										
FUND 727 GREENWOOD CEMETERY P-CARE										

PREPARED 07/01/2020, 10:57:29
PROGRAM GM360L
CITY OF CEDAR FALLS

ACCOUNT ACTIVITY LISTING

PAGE 31
ACCOUNTING PERIOD 12/2020

Item 3.

GROUP	PO	ACCTG	---TRANSACTION---						CURRENT
NBR	NBR	PER.	CD	DATE	NUMBER	DESCRIPTION	DEBITS	CREDITS	BALANCE
									POST DT
FUND 728	FAIRVIEW	CEMETERY	P-CARE						
FUND 729	HILLSIDE	CEMETERY	P-CARE						
FUND 790	FLOOD	LEVY							
					GRAND TOTAL		329,757.54	5,098.44	324,659.10

Council Invoices for Council Meeting 07/06/20

PREPARED 07/01/2020, 10:25:50
 PROGRAM GM360L
 CITY OF CEDAR FALLS

ACCOUNT ACTIVITY LISTING

PAGE 1
 ACCOUNTING PERIOD 12/2020

Item 3.

GROUP	PO	ACCTG	----TRANSACTION----	DEBITS	CREDITS	CURRENT
NBR	NBR	PER.	CD DATE NUMBER DESCRIPTION			BALANCE
----- POST DT -----						
FUND 101 GENERAL FUND						
101-1008-441.86-01			REPAIR & MAINTENANCE / REPAIR & MAINTENANCE			
2118	12/20	AP 06/07/20	0000000 SHRED-IT USA	48.95		07/01/20
			ON-SITE DOC. DESTRUCTION TICKET #8059930604			
ACCOUNT TOTAL				48.95	.00	48.95
101-1008-441.87-01			RENTALS / RENTALS			
11	01/21	AP 06/13/20	0000000 QUADIENT, INC.	162.00		07/01/20
			POSTAGE METER RENTAL 7/13/20-10/12/20			
ACCOUNT TOTAL				162.00	.00	162.00
101-1028-441.81-53			PROFESSIONAL SERVICES / JOB NOTICES			
2166	12/20	AP 06/28/20	0000000 COURIER COMMUNICATIONS-ADVERT	244.50		07/01/20
			JOB AD:REC PROG MGR. COURIER			
2166	12/20	AP 06/23/20	0000000 COURIER COMMUNICATIONS-ADVERT	39.00		07/01/20
			SEARCH BOOST			
2166	12/20	AP 06/14/20	0000000 COURIER COMMUNICATIONS-ADVERT	178.00		07/01/20
			JOB AD:ADMIN.SUPERVISOR BILLBOARD IMPRESSIONS			
2166	12/20	AP 06/07/20	0000000 COURIER COMMUNICATIONS-ADVERT	64.00		07/01/20
			JOB AD:ADMIN.SUPERVISOR COURIER			
2166	12/20	AP 06/07/20	0000000 COURIER COMMUNICATIONS-ADVERT	467.00		07/01/20
			30K IMPRESSIONS ONLINE			
2166	12/20	AP 06/06/20	0000000 COURIER COMMUNICATIONS-ADVERT	87.80		07/01/20
			JOB AD:PLANNER II BILLBOARD ONLINE			
2166	12/20	AP 06/02/20	0000000 COURIER COMMUNICATIONS-ADVERT	49.25		07/01/20
			JOB AD:PT OFFICE ASSIST. PULSE			
2166	12/20	AP 06/02/20	0000000 COURIER COMMUNICATIONS-ADVERT	22.50		07/01/20
			JOB AD:PT ADMIN.ASSIST. PULSE			
2166	12/20	AP 06/02/20	0000000 COURIER COMMUNICATIONS-ADVERT	64.00		07/01/20
			JOB AD:PLANNER II PULSE			
2166	12/20	AP 06/02/20	0000000 COURIER COMMUNICATIONS-ADVERT	64.00		07/01/20
			JOB AD:ADMIN.SUPERVISOR PULSE			
2114	12/20	AP 05/31/20	0000000 REGISTER MEDIA	120.00		07/01/20
			JOB AD:ENGINEER TECH II 5/19/20 DIGITAL			
2114	12/20	AP 05/31/20	0000000 REGISTER MEDIA	500.00		07/01/20
			JOB AD:ENGINEER TECH II 5/21/20 DIGITAL			
2114	12/20	AP 05/31/20	0000000 REGISTER MEDIA	60.00		07/01/20
			JOB AD:PLANNER II 5/26/20 DIGITAL			
2114	12/20	AP 05/31/20	0000000 REGISTER MEDIA	60.00		07/01/20
			JOB AD:PLANNER II 5/26/20 DIGITAL			
2114	12/20	AP 05/31/20	0000000 REGISTER MEDIA	500.00		07/01/20
			JOB AD:PLANNER II 5/28/20 DIGITAL			
2114	12/20	AP 05/31/20	0000000 REGISTER MEDIA	360.00		07/01/20
			JOB AD:ENGINEER TECH II 5/17/20 PACKAGE			
2114	12/20	AP 05/31/20	0000000 REGISTER MEDIA	360.00		07/01/20
			JOB AD:PLANNER II 5/24/20 PACKAGE			
2114	12/20	AP 05/31/20	0000000 REGISTER MEDIA	208.35		07/01/20

GROUP NBR	PO NBR	ACCTG PER.	CD	DATE	TRANSACTION NUMBER	DESCRIPTION	DEBITS	CREDITS	CURRENT BALANCE	POST DT
FUND 101 GENERAL FUND										
101-1028-441.81-53 PROFESSIONAL SERVICES / JOB NOTICES						continued				
2114				12/20	AP 05/31/20 0000000	JOB AD:PLANNER II REGISTER MEDIA	208.35			07/01/20
						JOB AD:ENGINEER TECH II 5/21/20-5/31/20 PACKAGE				
ACCOUNT TOTAL							3,656.75	.00	3,656.75	
101-1028-441.81-56 PROFESSIONAL SERVICES / EMPLOYEE WELLNESS PROG										
2166				12/20	AP 06/25/20 0000000	CINTAS FIRST AID & SAFETY	14.07			07/01/20
2114				12/20	AP 06/19/20 0000000	RESTOCK FIRST AID CABINET MYERS-COX COMPANY	785.99			07/01/20
						FY20 WELLNESS SNACKS				
ACCOUNT TOTAL							800.06	.00	800.06	
101-1048-441.81-29 PROFESSIONAL SERVICES / LEGAL CONSULTANTS										
2114				12/20	AP 06/01/20 0000000	REDFERN,MASON,LARSEN & MOORE, 5/7/20-5/18/20	440.00			07/01/20
2132				12/20	AP 06/01/20 0000000	LGL:GENERAL MATTERS REDFERN,MASON,LARSEN & MOORE, 05/06/20-05/29/20	2,783.50			07/01/20
PROJECT#:					023006					
11				01/21	AP 07/01/20 0000000	AHLERS AND COONEY, P.C. LEGAL SERVICES-JULY '20	3,900.00			07/01/20
11				01/21	AP 07/01/20 0000000	SWISHER & COHRT, P.L.C. LEGAL SERVICES-JULY '20	2,600.00			07/01/20
ACCOUNT TOTAL							9,723.50	.00	9,723.50	
101-1048-441.81-30 PROFESSIONAL SERVICES / LEGAL-CODE ENFORCEMENT										
11				01/21	AP 07/01/20 0000000	SWISHER & COHRT, P.L.C. LEGAL SERVICES-JULY '20	1,000.00			07/01/20
ACCOUNT TOTAL							1,000.00	.00	1,000.00	
101-1048-441.81-99 PROFESSIONAL SERVICES / CIVIL SERVICE COMMISSION										
2118				12/20	AP 06/19/20 0000000	STANARD & ASSOCIATES,INC. PSO APPLICANT TESTING	109.00			07/01/20
ACCOUNT TOTAL							109.00	.00	109.00	
101-1118-441.83-04 TRANSPORTATION&EDUCATION / DUES & MEMBERSHIPS										
11				01/21	AP 07/01/20 0000000	INTERNATIONAL CITY/CO.MGMT.AS FY2021 DUES-R.GAINES 07/01/20-06/30/21	1,400.00			07/01/20
ACCOUNT TOTAL							1,400.00	.00	1,400.00	

GROUP	PO	ACCTG	----	TRANSACTION----					
NBR	NBR	PER.	CD	DATE	NUMBER	DESCRIPTION	DEBITS	CREDITS	CURRENT BALANCE POST DT ----
FUND 101 GENERAL FUND									
101-1158-441.72-01						OPERATING SUPPLIES / OPERATING SUPPLIES			
2114		12/20 AP		06/16/20	0000000	GIBSON SPECIALTY CO, ENGRAVE PLATES	21.00		07/01/20
						ACCOUNT TOTAL	21.00	.00	21.00
101-1158-441.83-06 TRANSPORTATION&EDUCATION / EDUCATION									
11		01/21 AP		07/01/20	0000000	IOWA LEAGUE-CITIES REG:THRIVE2020 CONF-GREEN	215.00		07/01/20
						ACCOUNT TOTAL	215.00	.00	215.00
101-1199-411.32-90 COMM PROTECTION GRANTS / GRANTS - POLICE EQUIPMENT									
2149		12/20 AP		02/03/20	0133665	MIDWEST DEFENSE SOLUTIONS, LL ACCOUNT CORRECTION		2,515.62	06/26/20
2149		12/20 AP		02/03/20	0133665	8 BALLISTIC VESTS MIDWEST DEFENSE SOLUTIONS, LL 8 BALLISTIC VESTS	2,517.50		06/26/20
						ACCOUNT TOTAL	2,517.50	2,515.62	1.88
101-1199-421.31-10 HUMAN DEVELOPMENT GRANTS / GRANTS - CULTURAL SERVICE									
2130		12/20 AP		06/18/20	0000000	GROTH, ROBYN	380.00		07/01/20
2130		12/20 AP		06/11/20	0000000	RESEARCH FEES FOR NUHN VAN DOREN'S, LLC	850.00		07/01/20
						KC FRANKS FRAMING WORK BERG FUNDED			
						ACCOUNT TOTAL	1,230.00	.00	1,230.00
101-1199-441.72-19 OPERATING SUPPLIES / PRINTING									
2114		12/20 AP		06/12/20	0000000	COURIER LEGAL COMMUNICATIONS	344.96		07/01/20
2114		6/1/20 CC		MTG.MINS/BILLS					
2114		12/20 AP		06/10/20	0000000	COURIER LEGAL COMMUNICATIONS	336.37		07/01/20
2114		12/20 AP		06/05/20	0000000	2019 SALARY PUBLICATION COURIER LEGAL COMMUNICATIONS	65.67		07/01/20
11		01/21 AP		06/02/20	0000000	ORD.2966-REZONE ANNEXED PROPERTY MUNICIPAL CODE CORPORATION	450.00		07/01/20
						ANNUAL SUPPORT FEE 6/1/20-5/31/21			
						ACCOUNT TOTAL	1,197.00	.00	1,197.00
101-1199-441.88-20 OUTSIDE AGENCIES / LOBBYIST									
11		01/21 AP		07/01/20	0000000	COPE MURPHY+CO LLP LOBBYING FEE-JULY'20	4,500.00		07/01/20
						ACCOUNT TOTAL	4,500.00	.00	4,500.00

GROUP	PO	ACCTG	----TRANSACTION----				DEBITS	CREDITS	CURRENT
NBR	NBR	PER.	CD	DATE	NUMBER	DESCRIPTION			BALANCE
									POST DT ----
FUND 101 GENERAL FUND									
101-1199-441.89-11 MISCELLANEOUS SERVICES / LEAGUE DUES									
11		01/21	AP	06/15/20	0000000	IOWA LEAGUE-CITIES	11,544.00		07/01/20
						2020-2021 MEMBERSHIP DUES			7/1/20-6/30/21
ACCOUNT TOTAL							11,544.00	.00	11,544.00
101-1199-441.89-13 MISCELLANEOUS SERVICES / CONTINGENCY									
11		01/21	AP	05/22/20	0000000	ASCAP	363.00		07/01/20
						ANNUAL MUSIC LICENSE FEE			
ACCOUNT TOTAL							363.00	.00	363.00
101-2235-412.71-01 OFFICE SUPPLIES / OFFICE SUPPLIES									
2133		12/20	AP	06/09/20	0000000	DES MOINES STAMP MFG. CO.	42.40		07/01/20
						PAYMENT APPROVAL STAMP			
2133		12/20	AP	06/08/20	0000000	PARKADE PRINTER, INC.	224.38		07/01/20
						#10 WINDOW ENVELOPES			
2149		12/20	AP	01/30/20	0133582	STOREY KENWORTHY	27.82		06/26/20
						BINDER			
ACCOUNT TOTAL							294.60	.00	294.60
101-2235-412.71-07 OFFICE SUPPLIES / CODE ENFORCEMENT SUPPLIES									
2133		12/20	AP	06/16/20	0000000	PROFESSIONAL LAWN CARE, LLC	142.50		07/01/20
						CODE ENF.MOW-1122 22ND ST			
2133		12/20	AP	06/16/20	0000000	PROFESSIONAL LAWN CARE, LLC	142.50		07/01/20
						CODE ENF.MOW-2125 22ND ST			
2149		12/20	AP	04/07/20	0134153	POLK'S LOCK SERVICE, INC.		50.00	06/26/20
						ACCOUNT CORRECTION			2 KEYS-FORD TRUCK
2149		12/20	AP	01/30/20	0133582	STOREY KENWORTHY		27.82	06/26/20
						ACCOUNT CORRECTION			BINDER
ACCOUNT TOTAL							285.00	77.82	207.18
101-2235-412.72-60 OPERATING SUPPLIES / SAFETY SUPPLIES									
2166		12/20	AP	06/25/20	0000000	CINTAS FIRST AID & SAFETY	9.86		07/01/20
						RESTOCK FIRST AID CABINET			
ACCOUNT TOTAL							9.86	.00	9.86
101-2235-412.86-01 REPAIR & MAINTENANCE / REPAIR & MAINTENANCE									
2149		12/20	AP	04/07/20	0134153	POLK'S LOCK SERVICE, INC.	50.00		06/26/20
						2 KEYS-FORD TRUCK			
ACCOUNT TOTAL							50.00	.00	50.00

GROUP	PO	ACCTG	-----TRANSACTION-----			DEBITS	CREDITS	CURRENT
NBR	NBR	PER.	CD	DATE	NUMBER	DESCRIPTION		BALANCE
								POST DT
FUND 101 GENERAL FUND								
101-2245-442	81-25	PROFESSIONAL SERVICES / PROMOTIONAL TAPES & ADS.						
2114		12/20	AP	06/16/20	0000000	AWARDS, GIFTS & ENGRAVING	670.00	07/01/20
		AWARDS-BUSINESS & INDUSTR						
		PROJECT#: 014000						
ACCOUNT TOTAL						670.00	.00	670.00
101-2253-423	72-30	OPERATING SUPPLIES / DROP IN EQUIP & SUPPLIES						
2099		12/20	AP	06/16/20	0000000	PRINT INNOVATIONS	180.00	07/01/20
		REC LOGO DECAL						
ACCOUNT TOTAL						180.00	.00	180.00
101-2253-423	72-31	OPERATING SUPPLIES / YOUTH SPORTS/ACTIVE EQUIP						
2099		12/20	AP	06/22/20	0000000	PIONEER MANUFACTURING CO.	149.00	07/01/20
		FIELD MARKER						
2099		12/20	AP	06/17/20	0000000	BSN SPORTS, INC.	477.00	07/01/20
		SMART HURDLES						
ACCOUNT TOTAL						626.00	.00	626.00
101-2253-423	72-32	OPERATING SUPPLIES / ADULT SPORTS SUPPLIES						
2099		12/20	AP	06/25/20	0000000	USA SOFTBALL OF IOWA	1,330.00	07/01/20
		ADULT TEAM REGISTRATIONS						
2099		12/20	AP	06/11/20	0000000	IOWA SPORTS SUPPLY, INC.	70.46	07/01/20
		HOME PLATE EXTENSIONS						
ACCOUNT TOTAL						1,400.46	.00	1,400.46
101-2253-423	72-41	OPERATING SUPPLIES / POOL CONCESSIONS						
2165		12/20	AP	06/18/20	0000000	ATLANTIC COCA-COLA	1,038.26	07/01/20
		CONCESSIONS						
ACCOUNT TOTAL						1,038.26	.00	1,038.26
101-2253-423	73-17	OTHER SUPPLIES / POOL CHEMICALS						
2165		12/20	AP	06/26/20	0000000	ACCO UNLIMITED CORPORATION	521.40	07/01/20
		POOL CHEMICALS						
2099		12/20	AP	06/19/20	0000000	ACCO UNLIMITED CORPORATION	358.50	07/01/20
		POOL CHEMICALS						
2099		12/20	AP	06/18/20	0000000	CARRICO AQUATIC RESOURCES INC	776.00	07/01/20
		POOL CHEMICALS						
2099		12/20	AP	06/15/20	0000000	ACCO UNLIMITED CORPORATION	918.60	07/01/20
		POOL CHEMICALS						
ACCOUNT TOTAL						2,574.50	.00	2,574.50

GROUP NBR	PO NBR	ACCTG PER.	CD	DATE	TRANSACTION NUMBER	DESCRIPTION	DEBITS	CREDITS	CURRENT BALANCE	POST DT
FUND 101 GENERAL FUND										
101-2253-423.86-31						REPAIR & MAINTENANCE / SWIM POOL REPAIR & MAINT.				
2165		12/20 AP		06/18/20	0000000	CEDAR VALLEY LAWN CARE	871.06			07/01/20
2099		12/20 AP		06/11/20	0000000	MATTHIAS LANDSCAPING CO.	5,616.85			07/01/20
2148		12/20 AP		05/31/20	0000000	NAPA AUTO PARTS	357.78			07/01/20
						PARTS & EXPENSES MAY 20				
						ACCOUNT TOTAL	6,845.69	.00		6,845.69
101-2253-423.89-06 MISCELLANEOUS SERVICES / INDOOR POOL OPERATIONS										
2099		12/20 AP		06/15/20	0000000	CEDAR FALLS COMMUNITY SCHOOLS	16,057.24			07/01/20
						POOL USAGE 2019-2020				BALANCE
						ACCOUNT TOTAL	16,057.24	.00		16,057.24
101-2280-423.73-01 OTHER SUPPLIES / REPAIR & MAINT. SUPPLIES										
2130		12/20 AP		06/17/20	0000000	POLK'S LOCK SERVICE, INC.	340.00			07/01/20
						BROKEN DOORKNOB REPLACE				AND REKEY.
						ACCOUNT TOTAL	340.00	.00		340.00
101-2280-423.81-01 PROFESSIONAL SERVICES / PROFESSIONAL SERVICES										
2130		12/20 AP		06/18/20	0000000	GROTH, ROBYN	370.00			07/01/20
						HONORARIUM FOR M. NUHN				ESSAY.
14		01/21 AP		06/26/20	0000000	BRUCHER, J DELFS	300.00			07/01/20
						CONCERT PERFORMANCE 7/9				PARTY ON THE PATIO
14		01/21 AP		06/26/20	0000000	RUTH, KARLA	250.00			07/01/20
						CONCERT PERFORMANCE 7/16				PARTY ON THE PATIO
						ACCOUNT TOTAL	920.00	.00		920.00
101-2280-423.86-01 REPAIR & MAINTENANCE / REPAIR & MAINTENANCE										
2130		12/20 AP		06/15/20	0000000	DENNIS C. CHRISTENSEN & SONS,	1,125.00			07/01/20
						PATIO 5'X5' SQUARES PATIO				
						ACCOUNT TOTAL	1,125.00	.00		1,125.00
101-4511-414.71-01 OFFICE SUPPLIES / OFFICE SUPPLIES										
2122		12/20 AP		06/18/20	0000000	STOREY KENWORTHY	178.70			07/01/20
						COPY PAPER				
						ACCOUNT TOTAL	178.70	.00		178.70

GROUP NBR	PO NBR	ACCTG PER.	CD	DATE	TRANSACTION NUMBER	DESCRIPTION	DEBITS	CREDITS	CURRENT BALANCE	POST DT
FUND 101 GENERAL FUND										
101-4511-414.72-02						OPERATING SUPPLIES / LAUNDRY				
2122				12/20	AP 06/15/20 0000000	CITY LAUNDERING CO.	3.00			07/01/20
						TOWELS-STATION #1				
2122				12/20	AP 06/15/20 0000000	CITY LAUNDERING CO.	21.00			07/01/20
						TOWELS;MATS-PSS BUILDING				
						ACCOUNT TOTAL	24.00	.00		24.00
101-4511-414.72-09						OPERATING SUPPLIES / EQUIPMENT REPAIR				
2122				12/20	AP 06/18/20 0000000	RACOM CORPORATION	150.00			07/01/20
						BATTERY-FIRE SUPV.RADIO				
2118				12/20	AP 06/11/20 0000000	MILLER FENCE CO., INC.	215.16			07/01/20
						NEW RECEIVERS-FUEL GATES AFTER HOURS ACCESS				
						ACCOUNT TOTAL	365.16	.00		365.16
101-4511-414.72-11						OPERATING SUPPLIES / DUES, BOOKS, MAGAZINES				
13				01/21	AP 05/04/20 0000000	NATIONAL FIRE PROTECTION ASSO	1,575.00			07/01/20
						MEMB.RENEWAL-ALL ACCESS THRU 07/24/21				
						ACCOUNT TOTAL	1,575.00	.00		1,575.00
101-4511-414.73-02						OTHER SUPPLIES / DORMITORY FURNISHINGS				
2122				12/20	AP 06/19/20 0000000	PREMIER FURNITURE & EQUIPMENT	530.00			07/01/20
						LOCKER BENCHES-BATHROOMS PS BUILDING				
						ACCOUNT TOTAL	530.00	.00		530.00
101-4511-414.73-10						OTHER SUPPLIES / HEADQUARTER SUPPLIES				
2118				12/20	AP 06/17/20 0000000	FAREWAY STORES INC. #190	8.50			07/01/20
						PROPANE REFILL-PSS BLDG.				
						ACCOUNT TOTAL	8.50	.00		8.50
101-4511-414.81-71						PROFESSIONAL SERVICES / CONSOLIDATED DISPATCH				
12				01/21	AP 06/23/20 0000000	BLACK HAWK CO.AUDITOR	30,373.20			07/01/20
						FY21 Q1 CONSOLIDATED COMM				
						ACCOUNT TOTAL	30,373.20	.00		30,373.20
101-4511-414.81-75						PROFESSIONAL SERVICES / NIRG				
13				01/21	AP 06/17/20 0000000	BLACK HAWK CO.TREASURER	19,630.00			07/01/20
						FY21 HAZMAT CONTRIBUTION				
						ACCOUNT TOTAL	19,630.00	.00		19,630.00

GROUP NBR	PO NBR	ACCTG PER.	CD	DATE	TRANSACTION NUMBER	DESCRIPTION	DEBITS	CREDITS	CURRENT BALANCE	POST DT
FUND 101 GENERAL FUND										
101-4511-2122	414.86-50	REPAIR & MAINTENANCE / SERVICE CONTRACTS								
	12/20 AP	06/02/20	0000000			CLEAN HARBORS ENV. SERVICE, I	1,369.92			07/01/20
						HAZ MAT DISPOSAL-GRENADES				
						ACCOUNT TOTAL	1,369.92	.00		1,369.92
101-4511-2122	414.89-40	MISCELLANEOUS SERVICES / UNIFORM ALLOWANCE								
	12/20 AP	06/18/20	0000000			COVER-ALL EMBROIDERY, INC.	14.00			07/01/20
						EMBROIDER JOB SHIRT				
						TROY PURDY				
2122	12/20 AP	05/18/20	0000000			WERTJES UNIFORMS	116.50			07/01/20
						UNIFORM ALLOWANCE-BOOTS				
						THOMAS BALTES				
2122	12/20 AP	05/05/20	0000000			WERTJES UNIFORMS	352.97			07/01/20
						PSO UNIFORM ALLOWANCE				
						TROY PURDY				
						ACCOUNT TOTAL	483.47	.00		483.47
101-5521-2118	415.71-01	OFFICE SUPPLIES / OFFICE SUPPLIES								
	12/20 AP	06/18/20	0000000			STOREY KENWORTHY	357.40			07/01/20
						COPY PAPER				
						ACCOUNT TOTAL	357.40	.00		357.40
101-5521-2118	415.72-01	OPERATING SUPPLIES / OPERATING SUPPLIES								
	12/20 AP	06/17/20	0000000			FAREWAY STORES INC. #190	8.49			07/01/20
						PROPANE REFILL-PSS BLDG.				
2122	12/20 AP	06/15/20	0000000			CITY LAUNDERING CO.	21.00			07/01/20
						TOWELS;MATS-PSS BUILDING				
2118	12/20 AP	06/12/20	0000000			POLK'S LOCK SERVICE, INC.	14.48			07/01/20
						KEYS FOR NEW PD#11				
2118	12/20 AP	06/07/20	0000000			SHRED-IT USA	48.07			07/01/20
						ON-SITE DOC. DESTRUCTION				
						TICKET #8059298242				
2166	12/20 AP	05/29/20	0000000			KWIK TRIP, INC.	720.00			07/01/20
						200 CAR WASH CARDS-PD				
						ACCOUNT TOTAL	812.04	.00		812.04
101-5521-2118	415.72-20	OPERATING SUPPLIES / OFFICERS EQUIPMENT								
	12/20 AP	06/01/20	0000000			WERTJES UNIFORMS	40.00			07/01/20
						OPT.EQUIP.-BELT KEEPERS				
						CHRISTIAN BAUMGARTNER				
2118	12/20 AP	05/20/20	0000000			WERTJES UNIFORMS	87.90			07/01/20
						DOUBLE MAGAZINE CASES-2				
						INVENTORY				
2118	12/20 AP	05/19/20	0000000			WERTJES UNIFORMS	17.00			07/01/20
						OPT.EQUIP.-BELT KEEPERS				
						TROY PURDY				
2118	12/20 AP	05/05/20	0000000			WERTJES UNIFORMS	519.89			07/01/20
						INTL.EQUIP.-NEW OFFICER				
						TROY PURDY				
2118	12/20 AP	05/05/20	0000000			WERTJES UNIFORMS	208.58			07/01/20

GROUP NBR	PO NBR	ACCTG PER.	CD	DATE	TRANSACTION NUMBER	DESCRIPTION	DEBITS	CREDITS	CURRENT BALANCE	POST DT
FUND 101 GENERAL FUND										
101-5521-415.72-20 OPERATING SUPPLIES / OFFICERS EQUIPMENT						continued				
2118				12/20	AP 04/29/20 0000000	INTL.EQUIP.-NEW OFFICER TROY PURDY KELTEK INCORPORATED	168.75			07/01/20
2149				12/20	AP 02/03/20 0133665	SHOTGUN RACK KEYS MIDWEST DEFENSE SOLUTIONS, LL		359.38		06/26/20
2149				12/20	AP 02/03/20 0133665	ACCOUNT CORRECTION 8 BALLISTIC VESTS		359.37		06/26/20
2149				12/20	AP 02/03/20 0133665	ACCOUNT CORRECTION 8 BALLISTIC VESTS MIDWEST DEFENSE SOLUTIONS, LL	357.50			06/26/20
						50% REIMBURSED BY GRANT				
						ACCOUNT TOTAL	1,399.62	718.75		680.87
101-5521-415.72-33 OPERATING SUPPLIES / POLICE AUXILIARY PROGRAM										
2118				12/20	AP 05/28/20 0000000	WERTJES UNIFORMS ADAM ARIES	143.00			07/01/20
						UNIFORM ALLOWANCE-POLOS				
						ACCOUNT TOTAL	143.00	.00		143.00
101-5521-415.81-70 PROFESSIONAL SERVICES / CONTRACT SERVICES										
12				01/21	AP 07/01/20 0000000	HAWKEYE COMMUNICATION/FANDEL 07/01/20-06/30/21	564.00			07/01/20
						FIRE CELL DIALER-PD ALARM				
						ACCOUNT TOTAL	564.00	.00		564.00
101-5521-415.81-71 PROFESSIONAL SERVICES / CONSOLIDATED DISPATCH										
12				01/21	AP 06/23/20 0000000	BLACK HAWK CO.AUDITOR	61,666.80			07/01/20
						FY21 Q1 CONSOLIDATED COMM				
						ACCOUNT TOTAL	61,666.80	.00		61,666.80
101-5521-415.83-04 TRANSPORTATION&EDUCATION / DUES & MEMBERSHIPS										
2118				12/20	AP 06/11/20 0000000	SECRETARY, STATE OF IOWA	30.00			07/01/20
						NOTARY APPL.-JEFF SCHULTZ				
						ACCOUNT TOTAL	30.00	.00		30.00
101-5521-415.83-06 TRANSPORTATION&EDUCATION / EDUCATION										
12				01/21	AP 04/10/20 0000000	BLACK HAWK CO.SHERIFF	500.00			07/01/20
						BHCO TRAINING RANGE FEE				
						07/01/20-06/30/21				
						ACCOUNT TOTAL	500.00	.00		500.00
101-5521-415.86-05 REPAIR & MAINTENANCE / EQUIPMENT REPAIRS										

GROUP	PO	ACCTG	---TRANSACTION---				DEBITS	CREDITS	CURRENT
NBR	NBR	PER.	CD	DATE	NUMBER	DESCRIPTION			BALANCE
									POST DT ---
FUND 101 GENERAL FUND									
101-5521-415.86-05 REPAIR & MAINTENANCE / EQUIPMENT REPAIRS						continued			
2118		12/20	AP	06/11/20	0000000	MILLER FENCE CO., INC. AFTER HOURS ACCESS	215.16		07/01/20
ACCOUNT TOTAL							215.16	.00	215.16
101-5521-415.89-40 MISCELLANEOUS SERVICES / UNIFORM ALLOWANCE									
2118		12/20	AP	05/28/20	0000000	WERTJES UNIFORMS	288.00		07/01/20
						CHRISTIAN BAUMGARTNER			
2118		12/20	AP	05/28/20	0000000	WERTJES UNIFORMS	27.50		07/01/20
						MARTY BECKNER			
2118		12/20	AP	05/21/20	0000000	WERTJES UNIFORMS	116.99		07/01/20
						GAVIN CARMAN			
2118		12/20	AP	05/05/20	0000000	WERTJES UNIFORMS	897.39		07/01/20
						TROY PURDY			
2118		12/20	AP	05/05/20	0000000	WERTJES UNIFORMS	72.90		07/01/20
						TROY PURDY			
ACCOUNT TOTAL							1,402.78	.00	1,402.78
101-5521-425.81-20 PROFESSIONAL SERVICES / HUMANE SOCIETY									
2118		12/20	AP	06/04/20	0000000	WATERLOO, CITY OF	5,722.00		07/01/20
						ANIMAL CALLS;5/1-5/31/20			
2118		12/20	AP	05/01/20	0000000	CEDAR BEND HUMANE SOCIETY	1,802.50		07/01/20
						MAY'20 ANIMAL SURRENDER			
ACCOUNT TOTAL							7,524.50	.00	7,524.50
101-6613-433.72-01 OPERATING SUPPLIES / OPERATING SUPPLIES									
2111		12/20	AP	06/17/20	0000000	STOKES WELDING	60.00		07/01/20
						MOWER BLADES			
2148		12/20	AP	05/31/20	0000000	NAPA AUTO PARTS	338.37		07/01/20
						PARTS & EXPENSES MAY 20			
ACCOUNT TOTAL							398.37	.00	398.37
101-6616-446.72-01 OPERATING SUPPLIES / OPERATING SUPPLIES									
2148		12/20	AP	06/19/20	0000000	MENARDS-CEDAR FALLS	31.14		07/01/20
						WATER SOFTNER SALT			
PROJECT#:						062510			
2148		12/20	AP	06/15/20	0000000	MENARDS-CEDAR FALLS	32.76		07/01/20
						BRACKETS FOR WELLNESS			
						BARRIERS PROJ 065211			
PROJECT#:						012020			
2121		12/20	AP	06/12/20	0000000	MARTIN BROS.DISTRIBUTING	453.03		07/01/20
						TOWELS, CLOROX, TISSUES,			
						SOAP, URINAL SCREEN, CLEANR			
PROJECT#:						062501			

GROUP NBR	PO NBR	ACCTG PER.	CD	DATE	TRANSACTION NUMBER	DESCRIPTION	DEBITS	CREDITS	CURRENT BALANCE	POST DT
FUND 101 GENERAL FUND										
101-6616-446.73-06 OTHER SUPPLIES / BUILDING REPAIR continued										
PLEXIGLASS AND STANDS COVID 062511 PUB SAFETY										
PROJECT#:		012020								
2067		12/20 AP		06/09/20	0000000	O'DONNELL ACE HARDWARE	29.99			07/01/20
LIGHTING REPAIR										
PROJECT#:		062506								
2121		12/20 AP		06/09/20	0000000	MENARDS-CEDAR FALLS	7.39			07/01/20
PLUMBLING REPAIR										
PROJECT#:		062506								
2121		12/20 AP		06/09/20	0000000	MENARDS-CEDAR FALLS	33.50			07/01/20
ELECTRICAL REPAIR										
PROJECT#:		062511								
2067		12/20 AP		06/08/20	0000000	MENARDS-CEDAR FALLS	7.99			07/01/20
SAMPLING VALVE - PLUMBING REPAIR										
PROJECT#:		062506								
2067		12/20 AP		06/08/20	0000000	MENARDS-CEDAR FALLS	33.18			07/01/20
SUPPLIES FOR PLUMBING REPAIR										
PROJECT#:		062506								
2067		12/20 AP		06/08/20	0000000	O'DONNELL ACE HARDWARE	4.69			07/01/20
PACKING VALVE - PLUMBING REPAIR										
PROJECT#:		062506								
2067		12/20 AP		06/05/20	0000000	O'DONNELL ACE HARDWARE	29.68			07/01/20
BATTERY, P-TRAP-PLUMBING REPAIR										
PROJECT#:		062506								
2067		12/20 AP		06/05/20	0000000	O'DONNELL ACE HARDWARE	1.69			07/01/20
ELBOW- PLUMBING REPAIR										
PROJECT#:		062506								
2067		12/20 AP		06/05/20	0000000	O'DONNELL ACE HARDWARE	8.99			07/01/20
PARTS- PLUMBING REPAIR										
PROJECT#:		062506								
2067		12/20 AP		06/03/20	0000000	O'DONNELL ACE HARDWARE	5.69			07/01/20
COUPLING-PLUMBING REPAIR										
PROJECT#:		062506								
2067		12/20 AP		06/03/20	0000000	O'DONNELL ACE HARDWARE	5.69			07/01/20
PVC DRAIN CONNECTOR - PLUMBING REPAIR										
PROJECT#:		062506								
2067		12/20 AP		05/28/20	0000000	FASTENAL COMPANY	1.92			07/01/20
DOOR REPAIR										
PROJECT#:		062506								
ACCOUNT TOTAL							1,373.54	0.00		1,373.54
101-6616-446.81-08 PROFESSIONAL SERVICES / PEST CONTROL										
PROJECT#:		062505								
2148		12/20 AP		06/19/20	0000000	PLUNKETT'S PEST CONTROL, INC	25.00			07/01/20
PEST CONTROL										
PROJECT#:		062505								
2148		12/20 AP		06/18/20	0000000	PLUNKETT'S PEST CONTROL, INC	40.00			07/01/20
PEST CONTROL										
PROJECT#:		062515								

GROUP NBR	PO NBR	ACCTG PER.	CD	DATE	TRANSACTION NUMBER	DESCRIPTION	DEBITS	CREDITS	CURRENT BALANCE	POST DT
FUND 101 GENERAL FUND										
101-6616-446.81-08 PROFESSIONAL SERVICES / PEST CONTROL						continued				
2148			AP	12/20	06/18/20 0000000	PLUNKETT'S PEST CONTROL, INC	204.50			07/01/20
					PROJECT#: 062507					
2148			AP	12/20	06/18/20 0000000	PLUNKETT'S PEST CONTROL, INC	40.00			07/01/20
					PROJECT#: 062507					
2067			AP	12/20	06/03/20 0000000	PLUNKETT'S PEST CONTROL, INC	15.00			07/01/20
					PROJECT#: 062510					
2067			AP	12/20	06/03/20 0000000	PLUNKETT'S PEST CONTROL, INC	15.00			07/01/20
					PROJECT#: 062510					
ACCOUNT TOTAL							339.50	.00	339.50	
101-6616-446.86-02 REPAIR & MAINTENANCE / BUILDINGS & GROUNDS										
2111			AP	12/20	06/18/20 0000000	CITY LAUNDERING CO.	40.00			07/01/20
					PROJECT#: 012020					
2121			AP	12/20	06/17/20 0000000	HARRIS CLEANING SERVICE, INC.	2,491.50			07/01/20
					PROJECT#: 012020					
2121			AP	12/20	06/16/20 0000000	CITY LAUNDERING CO.	30.00			07/01/20
					PROJECT#: 062501					
2148			AP	12/20	06/16/20 0000000	CONTROL INSTALLATIONS OF IOWA	185.33			07/01/20
					PROJECT#: 062503					
2121			AP	12/20	06/09/20 0000000	CHRISTIE DOOR COMPANY	155.00			07/01/20
					PROJECT#: 062511					
2121			AP	12/20	06/05/20 0000000	PLUMB TECH INC.	450.00			07/01/20
					PROJECT#: 062507					
2121			AP	12/20	06/05/20 0000000	PLUMB TECH INC.	493.85			07/01/20
					PROJECT#: 062511					
ACCOUNT TOTAL							3,845.68	.00	3,845.68	
101-6616-446.86-14 REPAIR & MAINTENANCE / MECH EQUIPMENT SERVICING										
2121			AP	12/20	06/16/20 0000000	IA.DIV.LABOR-BOILER/ELEVATOR	175.00			07/01/20
					PROJECT#: 062511					
2148			AP	12/20	06/12/20 0000000	AIRE SERV.OF THE CEDAR VALLEY	285.00			07/01/20
					PROJECT#: 062501					
2121			AP	12/20	06/08/20 0000000	AIRE SERV.OF THE CEDAR VALLEY	215.12			07/01/20

GROUP NBR	PO NBR	ACCTG PER.	CD	DATE	---TRANSACTION--- NUMBER	DESCRIPTION	DEBITS	CREDITS	CURRENT BALANCE POST DT ----
FUND 101 GENERAL FUND									
101-6616-446.86-14 REPAIR & MAINTENANCE / MECH EQUIPMENT SERVICING						continued			
HVAC REPAIR									
PROJECT#:	062505								
2121	12/20	AP	06/08/20	0000000	AIRE SERV.OF THE CEDAR VALLEY	169.00			07/01/20
HVAC REPAIR									
PROJECT#:	062507								
2121	12/20	AP	06/08/20	0000000	AIRE SERV.OF THE CEDAR VALLEY	1,100.00			07/01/20
HVAC REPAIR									
PROJECT#:	062501								
ACCOUNT TOTAL						1,944.12	.00		1,944.12
101-6616-446.86-30 REPAIR & MAINTENANCE / MAINTENANCE & UPKEEP									
2121	12/20	AP	06/16/20	0000000	C & C WELDING & SANDBLASTING	330.75			07/01/20
RAILING REPAIR									
PROJECT#:	062505								
2067	12/20	AP	06/05/20	0000000	PLUMB TECH INC.	509.70			07/01/20
BACKFLOW TESTING									
PROJECT#:	062506								
2067	12/20	AP	06/05/20	0000000	PLUMB TECH INC.	254.85			07/01/20
BACKFLOW PREVENTERS									
PROJECT#:	062501								
2067	12/20	AP	06/05/20	0000000	PLUMB TECH INC.	169.90			07/01/20
BACKFLOW PREVENTERS									
PROJECT#:	062503								
2067	12/20	AP	06/05/20	0000000	PLUMB TECH INC.	84.95			07/01/20
BACKFLOW PREVENTERS									
PROJECT#:	062506								
2067	12/20	AP	06/05/20	0000000	PLUMB TECH INC.	169.90			07/01/20
BACKFLOW PREVENTERS-									
PROJECT#:	062510								
2067	12/20	AP	06/05/20	0000000	PLUMB TECH INC.	424.75			07/01/20
BACKFLOW PREVENTERS-									
PROJECT#:	062511								
2148	12/20	AP	05/29/20	0000000	ALLIED GLASS PRODUCTS	75.00			07/01/20
DOOR REPAIR									
PROJECT#:	062509								
2121	12/20	AP	05/01/20	0000000	MILLER WINDOW SERVICE	140.00			07/01/20
WINDOW CLEANING									
PROJECT#:	062506								
2121	12/20	AP	05/01/20	0000000	MILLER WINDOW SERVICE	405.00			07/01/20
WINDOW CLEANING									
PROJECT#:	062509								
2121	12/20	AP	05/01/20	0000000	MILLER WINDOW SERVICE	79.00			07/01/20
WINDOW CLEANING									
PROJECT#:	062505								
2121	12/20	AP	05/01/20	0000000	MILLER WINDOW SERVICE	525.00			07/01/20
WINDOW CLEANING									
PROJECT#:	062501								

GROUP NBR	PO NBR	ACCTG PER.	CD	DATE	TRANSACTION NUMBER	DESCRIPTION	DEBITS	CREDITS	CURRENT BALANCE	POST DT
FUND 101 GENERAL FUND										
101-6616-446.86-30 REPAIR & MAINTENANCE / MAINTENANCE & UPKEEP						continued				
2121		12/20	AP	05/01/20	0000000	MILLER WINDOW SERVICE	440.00			07/01/20
						WINDOW CLEANING				
PROJECT#:					062503					
2121		12/20	AP	05/01/20	0000000	MILLER WINDOW SERVICE	213.00			07/01/20
						WINDOW CLEANING				
PROJECT#:					062507					
2121		12/20	AP	05/01/20	0000000	MILLER WINDOW SERVICE	675.00			07/01/20
						WINDOW CLEANING				
PROJECT#:					062511					
2121		12/20	AP	05/01/20	0000000	MILLER WINDOW SERVICE	75.00			07/01/20
						WINDOW CLEANING				
PROJECT#:					062515					
ACCOUNT TOTAL							4,571.80	.00		4,571.80
101-6625-432.72-60 OPERATING SUPPLIES / SAFETY SUPPLIES										
2166		12/20	AP	06/25/20	0000000	CINTAS FIRST AID & SAFETY	9.86			07/01/20
						RESTOCK FIRST AID CABINET				
ACCOUNT TOTAL							9.86	.00		9.86
101-6633-423.72-01 OPERATING SUPPLIES / OPERATING SUPPLIES										
2111		12/20	AP	06/18/20	0000000	O'DONNELL ACE HARDWARE	9.69			07/01/20
						PLUMBLING PARTS FOR				
						COMM GARDENS				
2148		12/20	AP	06/18/20	0000000	DIAMOND VOGEL PAINT - #52	35.85			07/01/20
						PAINT				
2111		12/20	AP	06/17/20	0000000	DXP ENTERPRISES, INC.	588.26			07/01/20
						SAFETY GLASSES				
2111		12/20	AP	06/11/20	0000000	O'DONNELL ACE HARDWARE	23.78			07/01/20
						BOLTS, CLIPS				
2111		12/20	AP	06/10/20	0000000	FASTENAL COMPANY	238.00			07/01/20
						HARNESSES				
2094		12/20	AP	06/09/20	0000000	O'DONNELL ACE HARDWARE	25.56			07/01/20
						PAINT FOR PLAQUES				
2094		12/20	AP	06/09/20	0000000	UTILITY EQUIPMENT COMPANY	219.95			07/01/20
						FOUNDATION REPAIR PLUMB				
						PARTS				
2111		12/20	AP	06/09/20	0000000	BLACK HAWK RENTAL	39.95			07/01/20
						CHAINSAW BAR				
2111		12/20	AP	06/09/20	0000000	OUTDOOR RECREATION PROD	2,758.00			07/01/20
						MULCH				
2111		12/20	AP	06/09/20	0000000	MENARDS-CEDAR FALLS	54.57			07/01/20
						CLAMPS, TIE DOWNS, THIMBLES				
2111		12/20	AP	06/08/20	0000000	FASTENAL COMPANY	4,082.68			07/01/20
						HARNESSES				
2094		12/20	AP	06/05/20	0000000	UTILITY EQUIPMENT COMPANY	23.13			07/01/20
						PAW PARK PLUMBLING REPAIR				
2111		12/20	AP	06/05/20	0000000	PLUMB SUPPLY COMPANY, LLC	213.27			07/01/20

GROUP	PO	ACCTG	---TRANSACTION---				DEBITS	CREDITS	CURRENT
NBR	NBR	PER.	CD	DATE	NUMBER	DESCRIPTION			BALANCE
									POST DT
FUND 101 GENERAL FUND									
101-6633-423.72-01 OPERATING SUPPLIES / OPERATING SUPPLIES						continued			
TOOLS									
2111		12/20	AP	06/05/20	0000000	WAPSIE PINES LAWN CARE/LANDSC	148.43		07/01/20
PLANTS									
2111		12/20	AP	06/03/20	0000000	STOKES WELDING	69.43		07/01/20
BOLTS AND SPIKES									
2148		12/20	AP	05/31/20	0000000	NAPA AUTO PARTS	2,152.95		07/01/20
PARTS & EXPENSES MAY 20									
ACCOUNT TOTAL							10,683.50	.00	10,683.50
101-6633-423.86-01 REPAIR & MAINTENANCE / REPAIR & MAINTENANCE									
2148		12/20	AP	06/22/20	0000000	STICKFORT ELECTRIC CO., INC.	6,077.00		07/01/20
ELECTRICAL WORK ORCHARD HILL PARK									
2094		12/20	AP	06/05/20	0000000	COOLEY PUMPING, LLC	85.00		07/01/20
DROP TOILET-TONDRO PRAY									
2094		12/20	AP	06/05/20	0000000	COOLEY PUMPING, LLC	105.00		07/01/20
DROP TOILET-EL DORADO PRK									
2148		12/20	AP	06/05/20	0000000	PLUMB TECH INC.	822.83		07/01/20
BACKFLOW PREVENTER TESTS									
ACCOUNT TOTAL							7,089.83	.00	7,089.83
FUND TOTAL							233,321.16	3,312.19	230,008.97
FUND 203 TAX INCREMENT FINANCING									
FUND 206 STREET CONSTRUCTION FUND									
206-6637-436.72-16 OPERATING SUPPLIES / TOOLS									
2148		12/20	AP	06/19/20	0000000	O'DONNELL ACE HARDWARE	10.69		07/01/20
RUBBER MALLET									
ACCOUNT TOTAL							10.69	.00	10.69
206-6637-436.73-32 OTHER SUPPLIES / STREETS									
2148		12/20	AP	06/25/20	0000000	BUILDERS SELECT LLC	62.38		07/01/20
LUMBER FOR FORMS									
2148		12/20	AP	06/25/20	0000000	O'DONNELL ACE HARDWARE	5.99		07/01/20
QUIKCRETE									
2148		12/20	AP	06/23/20	0000000	BUILDERS SELECT LLC	9.19		07/01/20
LUMBER FOR FORMS									
2148		12/20	AP	06/20/20	0000000	ASPRO, INC.	1,376.32		07/01/20
HOT MIX ASPHALT									
2111		12/20	AP	06/19/20	0000000	O'DONNELL ACE HARDWARE	10.69		07/01/20
HANDLE FOR ASPHALT RAKE									
2111		12/20	AP	06/18/20	0000000	O'DONNELL ACE HARDWARE	2.69		07/01/20
WATER ADAPTER FOR ROLLER									

GROUP	PO	ACCTG	----TRANSACTION----				DEBITS	CREDITS	CURRENT
NBR	NBR	PER.	CD	DATE	NUMBER	DESCRIPTION			BALANCE
									POST DT
FUND 206 STREET CONSTRUCTION FUND									
206-6637-436.73-32 OTHER SUPPLIES / STREETS						continued			
2111		12/20	AP	06/18/20	0000000	SCOOP FEED & SUPPLY, THE	76.25		07/01/20
						GRASS SEED-PRAIRIE ST			
						DITCH			
2121		12/20	AP	06/17/20	0000000	BUILDERS SELECT LLC	28.20		07/01/20
						LUMBER FOR FORMS			
2121		12/20	AP	06/17/20	0000000	UTILITY EQUIPMENT COMPANY	415.20		07/01/20
						TILE FOR VIKING PLACE			
2121		12/20	AP	06/16/20	0000000	BENTON'S READY MIX CONCRETE,	119.00		07/01/20
						TILE			
2121		12/20	AP	06/16/20	0000000	UTILITY EQUIPMENT COMPANY	830.40		07/01/20
						TILE ON VIKING PLACE			
2111		12/20	AP	06/13/20	0000000	ASPRO, INC.	223.16		07/01/20
						CSS-1 TACK FOR HOTPATCHER			
2111		12/20	AP	06/13/20	0000000	ASPRO, INC.	351.12		07/01/20
						HOTMIX ASPHALT			
2111		12/20	AP	06/11/20	0000000	BENTON'S READY MIX CONCRETE,	595.00		07/01/20
						WATERLOO ROAD CONCRETE			
2094		12/20	AP	06/06/20	0000000	ASPRO, INC.	620.40		07/01/20
						HOTMIX ASPHALT			
2148		12/20	AP	06/06/20	0000000	BMC AGGREGATES L.C.	407.87		07/01/20
						3/8 CHIP FOR SPRAY PATCH			
2094		12/20	AP	06/04/20	0000000	BITUMINOUS MATERIALS & SUPPLY	350.68		07/01/20
						CRS-2 EMUSION			
2067		12/20	AP	06/02/20	0000000	MENARDS-CEDAR FALLS	29.99		07/01/20
						GARDEN STAPLES - EROSION			
						BLANKETS			
2094		12/20	AP	05/31/20	0000000	BMC AGGREGATES L.C.	840.65		07/01/20
						CLASS E RIP RAP FOR			
						UPCOMING PROJECT			
2094		12/20	AP	05/31/20	0000000	BMC AGGREGATES L.C.	725.34		07/01/20
						ROADSTONE FOR SHOULDERS			
2148		12/20	AP	05/31/20	0000000	NAPA AUTO PARTS	231.93		07/01/20
						PARTS & EXPENSES MAY 20			
2094		12/20	AP	05/29/20	0000000	BITUMINOUS MATERIALS & SUPPLY	355.95		07/01/20
						CRS-2 EMUSION			
2094		12/20	AP	05/28/20	0000000	BITUMINOUS MATERIALS & SUPPLY	372.91		07/01/20
						CRS-2 EMUSION			
						ACCOUNT TOTAL	8,041.31	.00	8,041.31
206-6647-436.72-01 OPERATING SUPPLIES / OPERATING SUPPLIES									
2148		12/20	AP	06/18/20	0000000	RHOMAR INDUSTRIES, INC	421.81		07/01/20
						PAINT REMOVER			
2111		12/20	AP	06/12/20	0000000	ECHO GROUP, INC.	106.39		07/01/20
						ELECTRICAL PARTS			
2094		12/20	AP	06/09/20	0000000	LAWSON PRODUCTS, INC.	91.43		07/01/20
						HARDWARE			
						ACCOUNT TOTAL	619.63	.00	619.63

GROUP NBR	PO NBR	ACCTG PER.	CD	DATE	TRANSACTION NUMBER	DESCRIPTION	DEBITS	CREDITS	CURRENT BALANCE	POST DT
FUND 206 STREET CONSTRUCTION FUND										
206-6647-436.72-16						OPERATING SUPPLIES / TOOLS				
2111			AP	06/09/20	0000000	CAMPBELL SUPPLY WATERLOO	71.76			07/01/20
						TOOLS				
2094			AP	06/08/20	0000000	CAMPBELL SUPPLY WATERLOO	41.92			07/01/20
						SCREWDRIVERS				
2067			AP	05/29/20	0000000	CAMPBELL SUPPLY WATERLOO	372.08			07/01/20
						TOOLS				
ACCOUNT TOTAL							485.76	0.00	485.76	
206-6647-436.92-01 STRUCTURE IMPROV & BLDGS / STRUCTURE IMPROV & BLDGS										
2121			AP	06/22/20	0000000	TRAFFIC CONTROL CORPORATION	13,750.00			07/01/20
						TRAFFIC CABINET FOR STOCK				
2094			AP	06/15/20	0000000	DIAMOND VOGEL PAINT - #64/#55	971.40			07/01/20
						TRAFFIC PAINT				
2067			AP	06/11/20	0000000	DIAMOND VOGEL PAINT - #64/#55	2,330.50			07/01/20
						REFLECTIVE GLASS BEADS				
2067			AP	06/11/20	0000000	TRAFFIC CONTROL CORPORATION	9,900.00			07/01/20
						SOLAR FLASH BEACON RE-PLACEMENT				
ACCOUNT TOTAL							26,951.90	0.00	26,951.90	
FUND TOTAL							36,109.29	0.00	36,109.29	
FUND 215 HOSPITAL FUND										
FUND 216 POLICE BLOCK GRANT FUND										
FUND 217 SECTION 8 HOUSING FUND										
FUND 223 COMMUNITY BLOCK GRANT										
FUND 224 TRUST & AGENCY										
FUND 242 STREET REPAIR FUND										
242-1240-431.92-44						STRUCTURE IMPROV & BLDGS / STREET RECONSTRUCTION				
2132			AP	06/11/20	0000000	PETERSON CONTRACTORS	385,854.31			07/01/20
						3185-2020 STREET CONST.				
						PROJECT#: 023185				
2132			AP	05/28/20	0000000	PETERSON CONTRACTORS	78,455.62			07/01/20
						3185-2020 STREET CONST.				
						PROJECT#: 023185				
ACCOUNT TOTAL							464,309.93	0.00	464,309.93	
242-1240-431.92-91 STRUCTURE IMPROV & BLDGS / 12TH ST. RECONSTRUCTION										
2132			AP	06/12/20	0000000	PETERSON CONTRACTORS	78,820.53			07/01/20
						3196-12TH ST.RECONSTRUCT.				
						PROJECT#: 023196				
ACCOUNT TOTAL							78,820.53	0.00	78,820.53	

PREPARED 07/01/2020, 10:25:50
 PROGRAM GM360L
 CITY OF CEDAR FALLS

ACCOUNT ACTIVITY LISTING

PAGE 19
 ACCOUNTING PERIOD 12/2020

GROUP NBR	PO NBR	ACCTG PER.	CD	DATE	TRANSACTION NUMBER	DESCRIPTION	DEBITS	CREDITS	CURRENT BALANCE POST DT
FUND 242 STREET REPAIR FUND									
FUND TOTAL							543,130.46	.00	543,130.46
FUND 254 CABLE TV FUND									
254-1088-431.73-01					OTHER SUPPLIES / REPAIR & MAINT. SUPPLIES				
2114		12/20 AP	06/10/20	0000000	FEDERAL EXPRESS	16.82			07/01/20
					SHIPPING-CLARK WIRE				
ACCOUNT TOTAL							16.82	.00	16.82
254-1088-431.93-01 EQUIPMENT / EQUIPMENT									
2114		12/20 AP	06/17/20	0000000	FEDERAL EXPRESS	449.28			07/01/20
					SHIPPING-ALLIED BROADCAST				
ACCOUNT TOTAL							449.28	.00	449.28
FUND TOTAL							466.10	.00	466.10
FUND 258 PARKING FUND									
258-5531-435.81-48					PROFESSIONAL SERVICES / CONTRACT SERVICES				
2166		12/20 AP	05/31/20	0000000	DUNCAN SOLUTIONS, INC.	2,152.94			07/01/20
					PARKING FEES-MAY-2020				
2131		12/20 AP	09/30/19	0132742	DUNCAN SOLUTIONS, INC.		3,435.52		06/24/20
					VOID CHECK-NOT NEEDED				
					PARKING FEES-SEPT 2019				
ACCOUNT TOTAL							2,152.94	3,435.52	1,282.58-
FUND TOTAL							2,152.94	3,435.52	1,282.58-
FUND 261 TOURISM & VISITORS									
261-2291-423.73-55					OTHER SUPPLIES / MEDIA				
2155		12/20 AP	06/25/20	0000000	PREMIER TRAVEL MEDIA	1,355.00			07/01/20
					IA TOUR GUIDE - JUNE 2020				
2155		12/20 AP	06/20/20	0000000	MINNESOTA TRAILS	1,080.00			07/01/20
					1/4 AD SPRING 2020				
2101		12/20 AP	06/09/20	0000000	IOWA DESTINATION MARKETING AL	2,500.00			07/01/20
					IDMA DIGITAL MARKETING				
					SPONSORSHIP-SILVER LEVEL				
2101		12/20 AP	05/31/20	0000000	ZLR IGNITION	576.25			07/01/20
					CLIENT ADMIN/COPYWRITING/				
					MEDIA MNGMT/REPORT				
2101		12/20 AP	05/31/20	0000000	ZLR IGNITION	3,687.73			07/01/20
					FACEBOOK/GOOGLE/TWITTER				
ACCOUNT TOTAL							9,198.98	.00	9,198.98

ACCOUNT ACTIVITY LISTING

GROUP NBR	PO NBR	ACCTG PER.	CD	DATE	---TRANSACTION--- NUMBER	DESCRIPTION	DEBITS	CREDITS	CURRENT BALANCE POST DT ----
FUND 261 TOURISM & VISITORS									
2101		12/20 AP	06/12/20	0000000	261-2291-423.73-57	OTHER SUPPLIES / GIFT SHOP FABRICATE, LLC	62.00		07/01/20
2101		12/20 AP	06/10/20	0000000	261-2291-423.83-06	CARDS/STICKERS/MAGNETS KATE BRENNAN HALL ILLUSTR. & PR 33 CARDS	49.50		07/01/20
ACCOUNT TOTAL							111.50	.00	111.50
261-2291-423.83-06 TRANSPORTATION&EDUCATION / EDUCATION									
15		01/21 AP	06/17/20	0000000	261-2291-423.85-20	DESTINATION MARKETING ASSOC. ANNUAL MEETING - VIRTUAL 7/14/20-7/15/20 PROJECT#: 032424	299.00		07/01/20
ACCOUNT TOTAL							299.00	.00	299.00
261-2291-423.85-20 UTILITIES / INTERNET SERVICE									
15		01/21 AP	07/01/20	0000000	261-2291-423.85-52	SPINUTECH WEB DESIGN, INC. JUL-SEPT HOST/LICENSE/ SUPPORT FEE	570.00		07/01/20
ACCOUNT TOTAL							570.00	.00	570.00
261-2291-423.85-52 UTILITIES / TOURISM MARKETING GRANTS									
2155		12/20 AP	06/18/20	0000000	261-2291-423.85-52	CEDAR VALLEY SPORTS COMMISSIO EMERGENCY FUNDING DUE TO COVID-19	10,000.00		07/01/20
ACCOUNT TOTAL							10,000.00	.00	10,000.00
FUND TOTAL							20,179.48	.00	20,179.48
FUND 262 SENIOR SERVICES & COMM CT									
FUND 291 POLICE FORFEITURE FUND									
2149		12/20 AP	02/03/20	0133665	291-5521-415.89-41	MISCELLANEOUS SERVICES / POLICE EQUIPMENT MIDWEST DEFENSE SOLUTIONS, LL ACCOUNT CORRECTION 8 BALLISTIC VESTS		2,515.63	06/26/20
2149		12/20 AP	02/03/20	0133665	291-5521-415.89-41	MISCELLANEOUS SERVICES / POLICE EQUIPMENT MIDWEST DEFENSE SOLUTIONS, LL 8 BALLISTIC VESTS 50% REIMBURSED BY GRANT	2,875.00		06/26/20
12		01/21 AP	05/19/20	0000000	291-5521-415.89-41	CELLEBRITE USA, INC. CELL PHONE DATA DOWNLOADR 07/13/20-07/12/21	3,700.00		07/01/20
ACCOUNT TOTAL							6,575.00	2,515.63	4,059.37
FUND TOTAL							6,575.00	2,515.63	4,059.37

GROUP NBR	PO NBR	ACCTG PER.	CD	DATE	TRANSACTION NUMBER	DESCRIPTION	DEBITS	CREDITS	CURRENT BALANCE	POST DT
FUND 292 POLICE RETIREMENT FUND										
FUND 293 FIRE RETIREMENT FUND										
FUND 294 LIBRARY RESERVE										
FUND 295 SOFTBALL PLAYER CAPITAL										
FUND 296 GOLF CAPITAL										
296-6623-423		92-01				STRUCTURE IMPROV & BLDGS / STRUCTURE IMPROV & BLDGS				
2121		12/20 AP		06/17/20	0000000	STICKFORT ELECTRIC CO., INC.	2,681.00			07/01/20
						WIRED UP NEW FUEL TANKS AT GREENWOOD CEMETERY				
2121		12/20 AP		06/17/20	0000000	STICKFORT ELECTRIC CO., INC.	2,090.00			07/01/20
						WIRED UP NEW FUEL TANKS AT GOLF COURSE PRO SHOP				
ACCOUNT TOTAL							4,771.00	.00	4,771.00	
FUND TOTAL							4,771.00	.00	4,771.00	
FUND 297 REC FACILITIES CAPITAL										
297-2253-423		92-01				STRUCTURE IMPROV & BLDGS / STRUCTURE IMPROV & BLDGS				
2133		12/20 AP		06/19/20	0000000	FAILOR HURLEY CONSTRUCTION	68,138.75			07/01/20
						3236-REC LOCKER ROOM UPG. #2				
PROJECT#:						023236				
ACCOUNT TOTAL							68,138.75	.00	68,138.75	
FUND TOTAL							68,138.75	.00	68,138.75	
FUND 298 HEARST CAPITAL										
FUND 311 DEBT SERVICE FUND										
FUND 402 WASHINGTON PARK FUND										
FUND 404 FEMA										
FUND 405 FLOOD RESERVE FUND										
FUND 407 VISION IOWA PROJECT										
FUND 408 STREET IMPROVEMENT FUND										
FUND 430 2004 TIF BOND										
FUND 430 2004 TIF BOND										
FUND 430 2004 TIF BOND										
430-1220-431		97-52				TIF BOND PROJECTS / PETER MELENDY PARK				
2132		12/20 AP		06/08/20	0000000	MILLER FENCE CO., INC.	2,859.99			07/01/20
						3208-PETER MELENDY PARK FLAGPOLE & FLAG				
PROJECT#:						023208				
ACCOUNT TOTAL							2,859.99	.00	2,859.99	
430-1220-431		97-82				TIF BOND PROJECTS / STREETSCAPE MAINTENANCE				
2111		12/20 AP		06/19/20	0000000	GIERKE-ROBINSON COMPANY, INC.	15.44			07/01/20
						EXPANSION				
PROJECT#:						023188				

GROUP	PO	ACCTG	---TRANSACTION---				DEBITS	CREDITS	CURRENT
NBR	NBR	PER.	CD	DATE	NUMBER	DESCRIPTION			BALANCE
									POST DT ----
FUND 430 2004 TIF BOND									
430-1220-431.97-82						TIF BOND PROJECTS /	continued		
2148		12/20	AP	06/19/20	0000000	MENARDS-WATERLOO	64.90		07/01/20
						LOCKING SAND FOR PAVERS			
PROJECT#:					023188				
2148		12/20	AP	06/19/20	0000000	MENARDS-CEDAR FALLS	19.14		07/01/20
						EXPANSION SEALANT			
PROJECT#:					023188				
2148		12/20	AP	06/19/20	0000000	MENARDS-CEDAR FALLS	19.14		07/01/20
						EXPANSION SEALANT			
PROJECT#:					023188				
2121		12/20	AP	06/17/20	0000000	BENTON'S READY MIX CONCRETE,	317.25		07/01/20
						CONCRETE FOR STREET			
						SCAPE HUB			
2121		12/20	AP	06/16/20	0000000	BENTON'S READY MIX CONCRETE,	743.75		07/01/20
						CONCRETE FOR SIDEWALK			
						BEHIND 6TH ST HUB			
PROJECT#:					023188				
2132		12/20	AP	06/12/20	0000000	CUNNINGHAM CONSTRUCTION CO.,	109,647.79		07/01/20
						3180-DOWNTOWN STREETScape			
PROJECT#:					023180				
						ACCOUNT TOTAL	110,827.41	.00	110,827.41
						FUND TOTAL	113,687.40	.00	113,687.40
FUND 431 2014 BOND									
FUND 432 2003 BOND									
FUND 433 2001 TIF									
FUND 434 2000 BOND									
FUND 435 1999 TIF									
FUND 436 2012 BOND									
436-1220-431.95-12						BOND FUND PROJECTS /			
2132		12/20	AP	06/23/20	0000000	GREENHILL ROAD EXTENSION			
						PETERSON CONTRACTORS	74,158.45		07/01/20
						1824-GREENHILL RD. EXTEN.			
PROJECT#:					021824				
						ACCOUNT TOTAL	74,158.45	.00	74,158.45
436-1220-431.98-26						CAPITAL PROJECTS /			
2132		12/20	AP	06/29/20	0000000	DOWNTOWN LEVEE IMPROVEMNT			
						IOWA BRIDGE & CULVERT, LC	7,324.50		07/01/20
						1975-DOWNTN.LEVEE IMPROV.			
PROJECT#:					021975				
						ACCOUNT TOTAL	7,324.50	.00	7,324.50
						FUND TOTAL	81,482.95	.00	81,482.95

GROUP NBR	PO NBR	ACCTG PER.	CD	DATE	TRANSACTION NUMBER	DESCRIPTION	DEBITS	CREDITS	CURRENT BALANCE POST DT
FUND 437	2018	BOND							
FUND 438	2020	BOND FUND							
FUND 439	2008	BOND FUND							
FUND 443	CAPITAL PROJECTS								
443-1220-431.94-55	CAPITAL PROJECTS / NETWORK SURVEIL CAMERAS								
2114	12/20 AP	12/31/19	0000000			CEDAR FALLS UTILITIES	24,980.00		07/01/20
						DOWNTOWN CAMERA PROJECT			
ACCOUNT TOTAL							24,980.00	.00	24,980.00
FUND TOTAL							24,980.00	.00	24,980.00
FUND 472	PARKADE RENOVATION								
FUND 473	SIDEWALK ASSESSMENT								
FUND 483	ECONOMIC DEVELOPMENT								
FUND 484	ECONOMIC DEVELOPMENT LAND								
FUND 541	2018 STORM WATER BONDS								
FUND 544	2008 SEWER BONDS								
FUND 545	2006 SEWER BONDS								
FUND 546	SEWER IMPROVEMENT FUND								
FUND 547	SEWER RESERVE FUND								
FUND 548	1997 SEWER BOND FUND								
FUND 549	1992 SEWER BOND FUND								
FUND 550	2000 SEWER BOND FUND								
FUND 551	REFUSE FUND								
551-6685-426.81-20	PROFESSIONAL SERVICES / HUMANE SOCIETY								
2118	12/20 AP	06/04/20	0000000			WATERLOO, CITY OF	388.00		07/01/20
						DEER DISPOSAL;5/1-5/31/20			
ACCOUNT TOTAL							388.00	.00	388.00
551-6685-436.72-16	OPERATING SUPPLIES / TOOLS								
2094	12/20 AP	06/10/20	0000000			MENARDS-CEDAR FALLS	23.98		07/01/20
						HAMMER FOR 383			
2067	12/20 AP	06/08/20	0000000			MENARDS-CEDAR FALLS	74.99		07/01/20
						LADDER FOR TRANS STA			
						TRAILER			
ACCOUNT TOTAL							98.97	.00	98.97
551-6685-436.72-19	OPERATING SUPPLIES / PRINTING								
2094	12/20 AP	06/12/20	0000000			PARKADE PRINTER, INC.	195.35		07/01/20
						O/M LETTERHEAD			
2094	12/20 AP	06/11/20	0000000			PARKADE PRINTER, INC.	124.27		07/01/20
						O/M ENVELOPES			
ACCOUNT TOTAL							319.62	.00	319.62

GROUP	PO	ACCTG	---TRANSACTION---			DEBITS	CREDITS	CURRENT
NBR	NBR	PER.	CD	DATE	NUMBER			BALANCE
								POST DT ---
FUND 551 REFUSE FUND								
551-6685-436.72-99								OPERATING SUPPLIES / POSTAGE
2067		12/20 AP	06/13/20	0000000	UNITED PARCEL SERVICE	25.19		07/01/20
					UPS SHIPPING			
					ACCOUNT TOTAL	25.19	.00	25.19
551-6685-436.73-01 OTHER SUPPLIES / REPAIR & MAINT. SUPPLIES								
2067		12/20 AP	06/11/20	0000000	O'DONNELL ACE HARDWARE	13.13		07/01/20
					NUTS, BOLTS, HINGE STRAP			
					STYROFOAM DUMPSTER REPAIR			
2094		12/20 AP	06/10/20	0000000	MENARDS-CEDAR FALLS	20.54		07/01/20
					PARTS FOR RECYCLING ROLL			
					OFF DOORS			
					ACCOUNT TOTAL	33.67	.00	33.67
551-6685-436.73-05 OTHER SUPPLIES / OPERATING EQUIPMENT								
2067		12/20 AP	06/11/20	0000000	C & C WELDING & SANDBLASTING	536.97		07/01/20
					TRAILER REPAIR			
2148		12/20 AP	05/31/20	0000000	NAPA AUTO PARTS	128.78		07/01/20
					PARTS & EXPENSES MAY 20			
					ACCOUNT TOTAL	665.75	.00	665.75
551-6685-436.73-06 OTHER SUPPLIES / BUILDING REPAIR								
2121		12/20 AP	06/13/20	0000000	KOCH CONSTRUCTION, INC.	559.70		07/01/20
					RECYCLING ROOF REPAIR			
					ACCOUNT TOTAL	559.70	.00	559.70
551-6685-436.86-37 REPAIR & MAINTENANCE / REFUSE CART TRACKING SW								
2148		12/20 AP	06/17/20	0000000	SIEBER CONSULTING	69.32		07/01/20
					MDT REPAIR			
					ACCOUNT TOTAL	69.32	.00	69.32
551-6685-436.87-02 RENTALS / MATERIAL DISPOSAL/HANDLIN								
2094		12/20 AP	06/06/20	0000000	LIBERTY TIRE RECYCLING, LLC	512.47		07/01/20
					SCRAP TIRE RECYCLING			
					ACCOUNT TOTAL	512.47	.00	512.47
					FUND TOTAL	2,672.69	.00	2,672.69

GROUP	PO	ACCTG	---TRANSACTION---				DEBITS	CREDITS	CURRENT
NBR	NBR	PER.	CD	DATE	NUMBER	DESCRIPTION			BALANCE
									POST DT ----
FUND 552 SEWER RENTAL FUND									
552-6655-436.72-01						OPERATING SUPPLIES / OPERATING SUPPLIES			
2103		12/20 AP	06/02/20	0000000		CAMPBELL SUPPLY WATERLOO GLOVES	244.71		07/01/20
ACCOUNT TOTAL							244.71	.00	244.71
552-6655-436.72-53 OPERATING SUPPLIES / TV EQUIPMENT									
2103		12/20 AP	06/03/20	0000000		MID-IOWA SOLID WASTE EQUIPMEN HEADSET-TELEVISIONING/HYDRO	1,490.38		07/01/20
ACCOUNT TOTAL							1,490.38	.00	1,490.38
552-6655-436.72-60 OPERATING SUPPLIES / SAFETY SUPPLIES									
2103		12/20 AP	06/09/20	0000000		CINTAS FIRST AID & SAFETY 1ST AID CABINETS	79.00		07/01/20
ACCOUNT TOTAL							79.00	.00	79.00
552-6655-436.73-06 OTHER SUPPLIES / BUILDING REPAIR									
2103		12/20 AP	05/01/20	0000000		WBC MECHANICAL, INC. BOILER MTE	3,194.78		07/01/20
ACCOUNT TOTAL							3,194.78	.00	3,194.78
552-6655-436.73-27 OTHER SUPPLIES / IOWA ONE CALL									
2121		12/20 AP	06/17/20	0000000		IOWA ONE CALL IOWA ONE CALL MAY 2020	658.80		07/01/20
ACCOUNT TOTAL							658.80	.00	658.80
552-6655-436.86-12 REPAIR & MAINTENANCE / TOWELS									
2103		12/20 AP	06/15/20	0000000		CITY LAUNDERING CO. RUGS AND TOWELS	38.75		07/01/20
ACCOUNT TOTAL							38.75	.00	38.75
552-6655-436.92-01 STRUCTURE IMPROV & BLDGS / STRUCTURE IMPROV & BLDGS									
2103		12/20 AP	06/02/20	0000000		BLACK & VEATCH CORPORATION NUTRIENT REDUCTION PLAN	7,767.00		07/01/20
PROJECT#:		023210							
ACCOUNT TOTAL							7,767.00	.00	7,767.00

GROUP	PO	ACCTG	-----TRANSACTION-----			DESCRIPTION	DEBITS	CREDITS	CURRENT
NBR	NBR	PER.	CD	DATE	NUMBER			BALANCE	
								POST DT ----	
FUND 552 SEWER RENTAL FUND									
552-6665-436.72-26 OPERATING SUPPLIES / TESTING & LAB									
2103		12/20 AP	06/12/20	0000000		MIDLAND SCIENTIFIC, INC.	147.04		07/01/20
		LAB SUPPLIES							
2103		12/20 AP	06/10/20	0000000		MIDLAND SCIENTIFIC, INC.	633.08		07/01/20
		LAB SUPPLIES							
ACCOUNT TOTAL							780.12	.00	780.12
552-6665-436.73-05 OTHER SUPPLIES / OPERATING EQUIPMENT									
2103		12/20 AP	06/17/20	0000000		MENARDS-CEDAR FALLS	32.16		07/01/20
		WATER							
2103		12/20 AP	06/17/20	0000000		TRACTOR SUPPLY CO.	89.99		07/01/20
		ROUND UP							
2103		12/20 AP	06/12/20	0000000		CRESCENT ELECTRIC	11.90		07/01/20
		FINAL LS ELECTRICAL							
2103		12/20 AP	06/12/20	0000000		CRESCENT ELECTRIC	62.09		07/01/20
		FINAL LS ELECTRICAL							
2103		12/20 AP	06/12/20	0000000		O'DONNELL ACE HARDWARE	2.69		07/01/20
		PLUMBLING SUPPLY							
2103		12/20 AP	06/10/20	0000000		CRESCENT ELECTRIC	29.26		07/01/20
		FINAL LS ELECTRICAL							
2103		12/20 AP	06/10/20	0000000		O'DONNELL ACE HARDWARE	14.69		07/01/20
		SOCKET							
2103		12/20 AP	06/09/20	0000000		CRESCENT ELECTRIC	45.04		07/01/20
		FINAL LS ELECTRICAL							
2103		12/20 AP	06/09/20	0000000		CRESCENT ELECTRIC	183.69		07/01/20
		FINAL LS ELECTRICAL							
2103		12/20 AP	06/08/20	0000000		CRESCENT ELECTRIC	190.49		07/01/20
		LIFT STATION FINAL							
2103		12/20 AP	06/08/20	0000000		CRESCENT ELECTRIC	44.23		07/01/20
		FINAL LS ELECTRICAL							
ACCOUNT TOTAL							706.23	.00	706.23
552-6665-436.73-36 OTHER SUPPLIES / SAN. LIFT STATION SUPP.									
2103		12/20 AP	06/10/20	0000000		VAN METER, INC.	68.60		07/01/20
		LIFT STATION FINAL							
2103		12/20 AP	06/08/20	0000000		CRESCENT ELECTRIC	31.46		07/01/20
		LIFT STATION FINAL							
2103		12/20 AP	06/05/20	0000000		PLUMB TECH INC.	764.55		07/01/20
		LIFT STATION BACKFLOW							
2103		12/20 AP	06/03/20	0000000		CRESCENT ELECTRIC	2.19		07/01/20
		LIFT STATION FINAL							
ACCOUNT TOTAL							866.80	.00	866.80
552-6665-436.86-29 REPAIR & MAINTENANCE / LAB & TESTING									

GROUP	PO	ACCTG	---TRANSACTION---				DEBITS	CREDITS	CURRENT
NBR	NBR	PER.	CD	DATE	NUMBER	DESCRIPTION			BALANCE
									POST DT
FUND 552 SEWER RENTAL FUND									
552-6665-436.86-29 REPAIR & MAINTENANCE / LAB & TESTING						continued			
2103		12/20	AP	06/16/20	0000000	NORTHERN BALANCE & SCALE CO.	170.00		07/01/20
BALANCE CALIBRATION									
2103		12/20	AP	06/15/20	0000000	LONG CROP CONSULTING	1,920.00		07/01/20
CROP TESTING									
ACCOUNT TOTAL							2,090.00	.00	2,090.00
FUND TOTAL							17,916.57	.00	17,916.57
FUND 553 2004 SEWER BOND									
FUND 555 STORM WATER UTILITY									
555-2230-432.73-34 OTHER SUPPLIES / STORM SEWERS									
2121		12/20	AP	06/17/20	0000000	BENTON'S READY MIX CONCRETE, CONCRETE FOR CATCH BASINS	458.25		07/01/20
BOX									
2121		12/20	AP	06/16/20	0000000	UTILITY EQUIPMENT COMPANY	531.04		07/01/20
CASTING FOR LINCOLN ST									
2111		12/20	AP	06/15/20	0000000	BENTON'S READY MIX CONCRETE, CONCRETE-LINCOLN ST CATCH	352.50		07/01/20
BASIN									
2111		12/20	AP	06/11/20	0000000	BENTON'S READY MIX CONCRETE, CATCH BASIN CONCRETE	423.00		07/01/20
2067		12/20	AP	06/10/20	0000000	UTILITY EQUIPMENT COMPANY COVERS FOR MANHOLES	432.48		07/01/20
PERMEABLE ALLEY									
ACCOUNT TOTAL							2,197.27	.00	2,197.27
555-2230-432.86-20 REPAIR & MAINTENANCE / STORM SEWERS									
2148		12/20	AP	06/24/20	0000000	O'DONNELL ACE HARDWARE	47.92		07/01/20
QUIKCRETE									
2148		12/20	AP	06/24/20	0000000	O'DONNELL ACE HARDWARE	41.93		07/01/20
QUIKCRETE									
2121		12/20	AP	06/08/20	0000000	NEENAH FOUNDRY COMPANY	379.50		07/01/20
CASTING LIDS									
ACCOUNT TOTAL							469.35	.00	469.35
555-2230-432.92-01 STRUCTURE IMPROV & BLDGS / STRUCTURE IMPROV & BLDGS									
2132		12/20	AP	06/02/20	0000000	AECOM TECHNICAL SERVICES, INC	13,856.64		07/01/20
3215-OLIVE ST BOX CULVERT									
PROJECT#: 023215									
05/02/20-05/29/20									
ACCOUNT TOTAL							13,856.64	.00	13,856.64
FUND TOTAL							16,523.26	.00	16,523.26

ACCOUNT ACTIVITY LISTING

Item 3.

GROUP	PO	ACCTG	----TRANSACTION----			DEBITS	CREDITS	CURRENT
NBR	NBR	PER.	CD	DATE	NUMBER	DESCRIPTION		BALANCE
							POST DT	----
FUND 570 SEWER ASSESSMENT								
FUND 606 DATA PROCESSING FUND								
606-1078-441.71-01						OFFICE SUPPLIES / OFFICE SUPPLIES		
2114		12/20 AP		06/16/20	0000000	OFFICE DEPOT	64.01	07/01/20
						TONER-K ROGERS		
ACCOUNT TOTAL						64.01	.00	64.01
606-1078-441.82-30 COMMUNICATION / FIBER OPTICS								
2114		12/20 AP		12/31/19	0000000	CEDAR FALLS UTILITIES	278.00	07/01/20
						YEARLY FIBER MAINT FEE		
ACCOUNT TOTAL						278.00	.00	278.00
606-1078-441.86-10 REPAIR & MAINTENANCE / SOFTWARE SUPPORT AGREEMTS								
11		01/21 AP		07/01/20	0000000	SHIELD TECHNOLOGY CORPORATION	9,232.50	07/01/20
						ANNUAL SHIELDWARE MAINT.		
						07/2020-06/2021		
11		01/21 AP		06/02/20	0000000	IP PATHWAYS, LLC	15,692.34	07/01/20
						CISCO MAINT.RENEWAL		
						1 YEAR		
ACCOUNT TOTAL						24,924.84	.00	24,924.84
606-1078-441.93-01 EQUIPMENT / EQUIPMENT								
2114		12/20 AP		04/29/20	0000000	AERIAL SERVICES INC.	15,450.00	07/01/20
						GIS AERIAL PROJECT		
ACCOUNT TOTAL						15,450.00	.00	15,450.00
FUND TOTAL						40,716.85	.00	40,716.85
FUND 680 HEALTH INSURANCE FUND								
680-1902-457.51-01 INSURANCE / HEALTH INSURANCE								
11		01/21 AP		06/19/20	0000000	HOLMES MURPHY & ASSOCIATES LL	2,416.66	07/01/20
						BENEFITS CONSULTING SERV.		
						JULY 2020		
ACCOUNT TOTAL						2,416.66	.00	2,416.66
FUND TOTAL						2,416.66	.00	2,416.66

GROUP	PO	ACCTG	----TRANSACTION----				DEBITS	CREDITS	CURRENT
NBR	NBR	PER.	CD	DATE	NUMBER	DESCRIPTION			BALANCE
									POST DT ----
FUND 681 HEALTH SEVERANCE									
FUND 682 HEALTH INSURANCE - FIRE									
FUND 685 VEHICLE MAINTENANCE FUND									
685-6698-446.72-05						OPERATING SUPPLIES / GAS & OIL			
2148			AP	06/25/20	0000000	CONSOLIDATED ENERGY COMPANY	456.14		07/01/20
						#2 DIESEL TO GREENWOOD CEMETERY			
2067			AP	06/09/20	0000000	SAM ANNIS & CO.	107.20		07/01/20
						PROPANE TANK REFILL			
2067			AP	05/31/20	0000000	AIRGAS USA, LLC	67.58		07/01/20
						WELDING & CUTTING GAS			
2148			AP	05/31/20	0000000	NAPA AUTO PARTS	5,387.31		07/01/20
						PARTS & EXPENSES MAY 20			
ACCOUNT TOTAL							6,018.23	.00	6,018.23
685-6698-446.72-16 OPERATING SUPPLIES / TOOLS									
2111			AP	04/06/20	0000000	SPECIALIZED PETROLEUM SERVICE	1,995.00		07/01/20
						TRANSMISSION FLUSH MACH UPGRADE			
ACCOUNT TOTAL							1,995.00	.00	1,995.00
685-6698-446.72-60 OPERATING SUPPLIES / SAFETY SUPPLIES									
2148			AP	05/31/20	0000000	NAPA AUTO PARTS	108.86		07/01/20
						PARTS & EXPENSES MAY 20			
ACCOUNT TOTAL							108.86	.00	108.86
685-6698-446.73-04 OTHER SUPPLIES / VEHICLE SUPPLIES									
2148			AP	06/19/20	0000000	TOYNE, INC.	48.95		07/01/20
						FD501 PUSH BUITTON LATCH			
2111			AP	06/18/20	0000000	MENARDS-CEDAR FALLS	26.60		07/01/20
						ACCESS DOOR REPAIR AT POOL			
2121			AP	06/16/20	0000000	TOYNE, INC.	113.50		07/01/20
						COMPARTMENT SLIDE GAS SHOCKS FD502			
2067			AP	06/13/20	0000000	UNITED PARCEL SERVICE	19.85		07/01/20
						UPS SHIPPING			
2067			AP	06/10/20	0000000	GIERKE-ROBINSON COMPANY, INC.	46.07		07/01/20
						CARBURETOR FOR FIRE FAN			
2067			AP	06/10/20	0000000	POLK'S LOCK SERVICE, INC.	50.00		07/01/20
						SPARE KEY PD07			
2094			AP	06/09/20	0000000	LAWSON PRODUCTS, INC.	601.20		07/01/20
						MISC SHOP SUPPLIES			
2148			AP	05/31/20	0000000	NAPA AUTO PARTS	32,509.47		07/01/20
						PARTS & EXPENSES MAY 20			
ACCOUNT TOTAL							33,415.64	.00	33,415.64

GROUP	PO	ACCTG	----TRANSACTION----			DEBITS	CREDITS	CURRENT
NBR	NBR	PER.	CD	DATE	NUMBER			BALANCE
								POST DT ----
FUND 685 VEHICLE MAINTENANCE FUND								
685-6698-446.86-12								REPAIR & MAINTENANCE / TOWELS
2111		12/20	AP	06/18/20	0000000	35.00		CITY LAUNDERING CO. SHOP TOWELS
								07/01/20
						35.00	.00	ACCOUNT TOTAL
								35.00
685-6698-446.86-15 REPAIR & MAINTENANCE / TIRE REPAIRS								
2148		12/20	AP	05/31/20	0000000	443.00		NAPA AUTO PARTS PARTS & EXPENSES MAY 20
								07/01/20
						443.00	.00	ACCOUNT TOTAL
								443.00
685-6698-446.87-08 RENTALS / WORK BY OUTSIDE AGENCY								
2148		12/20	AP	06/22/20	0000000	497.61		MIDWEST OVERHEAD CRANE ANNUAL CRANE INSPECTION
								07/01/20
2148		12/20	AP	06/13/20	0000000	300.00		RASMUSSON CO., THE TOWED 372 TO PUBLIC WORKS
								07/01/20
2067		12/20	AP	06/09/20	0000000	200.00		CEDAR VALLEY AUTO GLASS INC. PD07 WINDSHIELD REPLACED
								07/01/20
2148		12/20	AP	06/09/20	0000000	200.00		RASMUSSON CO., THE TOWED 494 TO PUBLIC WORKS
								07/01/20
2148		12/20	AP	06/05/20	0000000	200.00		RASMUSSON CO., THE TOWED 320 TO PUBLIC WORKS
								07/01/20
2094		12/20	AP	05/13/20	0000000	45.00		RASMUSSON CO., THE PD#112TOWED TO PW
								07/01/20
2094		12/20	AP	05/11/20	0000000	45.00		RASMUSSON CO., THE PD#9 TOWED TO PW
								07/01/20
2094		12/20	AP	05/06/20	0000000	45.00		RASMUSSON CO., THE #701 TOWED TO PW
								07/01/20
						1,532.61	.00	ACCOUNT TOTAL
								1,532.61
685-6698-446.93-04 EQUIPMENT / REFURBISH VEHICLES								
2111		12/20	AP	06/11/20	0000000	825.00		SCHOOL BUS SALES #237 TOMMY GATE TAILGATE
								07/01/20
						825.00	.00	ACCOUNT TOTAL
								825.00
						44,373.34	.00	FUND TOTAL
								44,373.34

GROUP	PO	ACCTG	----TRANSACTION----				DEBITS	CREDITS	CURRENT
NBR	NBR	PER.	CD	DATE	NUMBER	DESCRIPTION			BALANCE
									POST DT ----
FUND 686 PAYROLL FUND									
FUND 687 WORKERS COMPENSATION FUND									
687-1902-457.51-02 INSURANCE / WORKERS COMP INSURANCE									
2166		12/20 AP		06/12/20	0000000	MERCYONE WATERLOO MEDICAL CEN	347.00		07/01/20
				5/11/20		W/C D DOUGLAS			
2166		12/20 AP		06/05/20	0000000	VAN WYNGARDEN & ABRAHAMSON, IN	524.10		07/01/20
				6/1/20		W/C D DOUGLAS			
2114		12/20 AP		06/01/20	0000000	REDFERN, MASON, LARSEN & MOORE,	60.00		07/01/20
						5/4/20			
2114		12/20 AP		06/01/20	0000000	REDFERN, MASON, LARSEN & MOORE,	10,738.25		07/01/20
						5/1/20-5/31/20			
ACCOUNT TOTAL							11,669.35	.00	11,669.35
FUND TOTAL							11,669.35	.00	11,669.35
FUND 688 LTD INSURANCE FUND									
FUND 689 LIABILITY INSURANCE FUND									
689-1902-457.51-05 INSURANCE / LIABILITY INSURANCE									
2114		12/20 AP		06/09/20	0000000	CEDAR VALLEY AUTO GLASS INC.	210.00		07/01/20
						DOL: 6/6/20			
ACCOUNT TOTAL							210.00	.00	210.00
FUND TOTAL							210.00	.00	210.00
FUND 724 TRUST & AGENCY									
FUND 727 GREENWOOD CEMETERY P-CARE									
FUND 728 FAIRVIEW CEMETERY P-CARE									
FUND 729 HILLSIDE CEMETERY P-CARE									
FUND 790 FLOOD LEVY									
GRAND TOTAL							1,271,493.25	9,263.34	1,262,229.91